

EAGLE GROUP

A Division of AIMCO



Production Tools

POWER TOOL SOLUTIONS

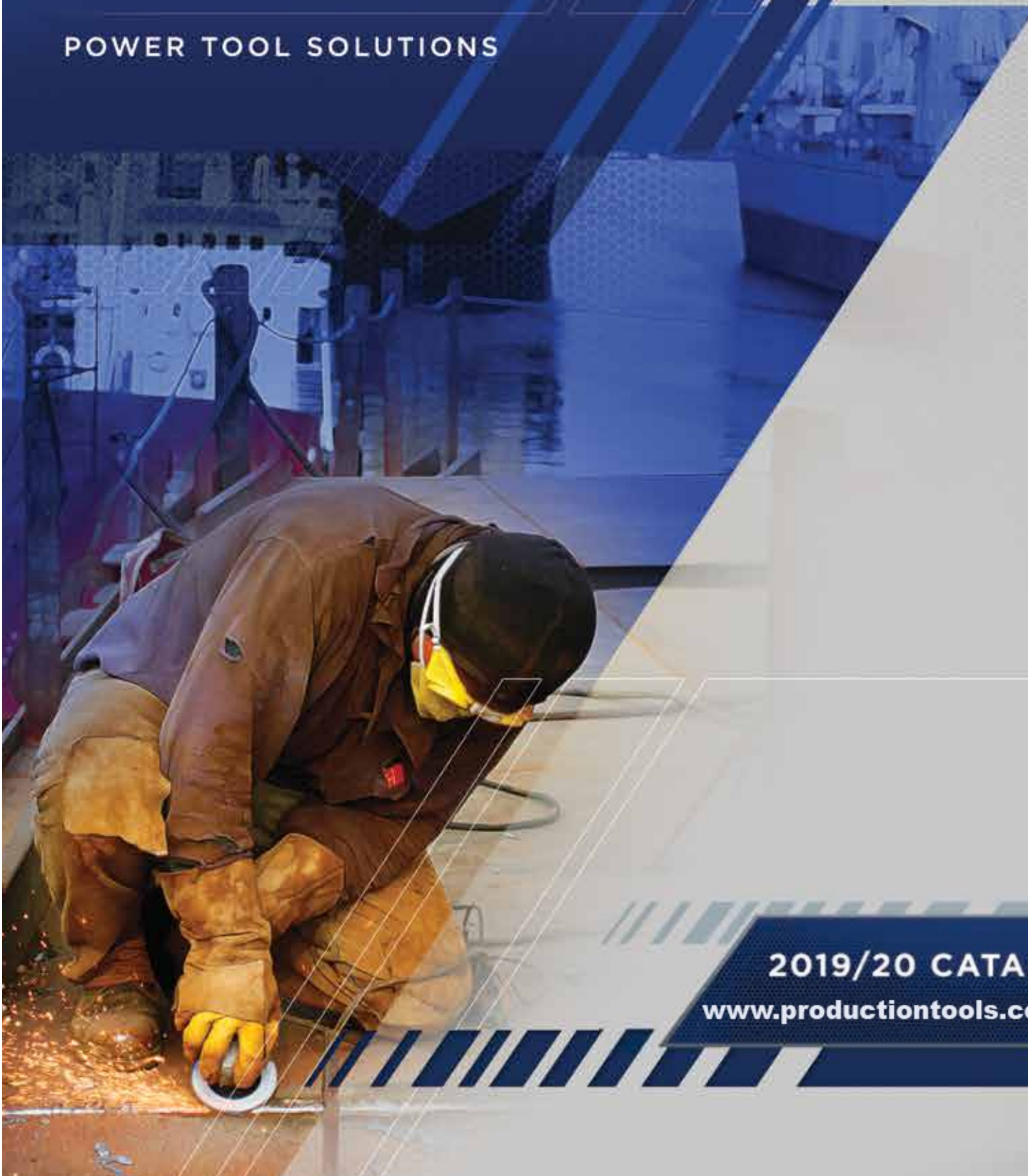

2019/20 CATALOG

www.productiontools.com.mx

5	GRINDERS
15	SANDERS
19	IMPACT WRENCHES
25	RATCHET WRENCHES
27	PULSE TOOLS
29	ASSEMBLY TOOLS
37	DRILLS
43	PERCUSSION TOOLS
47	CUTTING & SPECIALTY TOOLS
53	ACCESSORIES
71	RESOURCES



Production Tools S.A de C.V.
Av. Presidente Adolfo Lopez Mateos 8 Ex-Hacienda del Pedregal
Atizapan de Zaragoza Edo de Méx, México C.P. 52966
www.productiontools.com.mx
ventas@productiontools.com.mx
+52 53637600

THE EAGLE GROUP *DIFFERENCE*

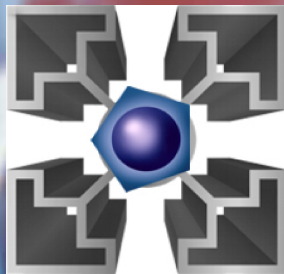

LLAMANOS
TE ATENDEREMOS CON GUSTO:

(52) 53637600

EAGLE GROUP

A portfolio designed for a variety of customers and customer use requirements

- Economic tool series for limited use, limited maintenance, or limited budget
- Ergonomic series for safer and more comfortable use
- Industrial and Premier series for specific process and safety improvements
- All supported under the AIMCO umbrella of service and support



MATERIAL REMOVAL

5040
Vertical
Grinder



5205-2EC
Angle Grinder



5002C
Die Grinder



5I-10202X Extended Die Grinder



5000 Pencil Grinder

Premier Series

GDB31-E18-CW
Horizontal
Grinder



GTB41-A60-DW-6
Turbine
Grinder



GAB41-A60-DW
Angle Grinder



FINISHING

6906EC Orbital
Sander



6134EC
Angle Sander



6116 Belt Sander



BOLTING

High Torque Pneumatic

AAP1B Series



AAP2B
High-Speed Series



DynaTorque
Manual Torque
Multipliers ATM-3800



CUTTING



6080 Reciprocating Saw



6050
Reciprocating Saw

5G-10125
5" Angle Saw



PERCUSSION

4009 Chipping Hammer



4260 Air Hammer



4005 Needle
Scaler



4004 Flux Chipper



DRILLING/TAPPING

738P-3200 Drill



7650 Angle Drill



7110 Reversible Drill



LIGHT ASSEMBLY

EPTS Series
Pneumatic Screwdrivers



1115 Positive Clutch
Screwdriver



1577 Impact
Screwdriver



Signature Series Cordless

SPC Series
Precision
Clutch



SIW Series
Shut-off
Impact



IMPACT WRENCHES

2010
3/8"
Single Hammer



2150
3/8" Twin Hammer



2263EC
1/2" Twin Hammer



2004
3/4" Single Hammer



2450 1" Twin Hammer



2S-290015
1-1/2" Swing Hammer



RATCHET WRENCHES



3115 1/4" Ratchet Wrench



3220 3/8" Ratchet Wrench

PULSE TOOLS

Screwdrivers



9020D
1/4"



9025
3/8"

GRINDERS

GRINDERS

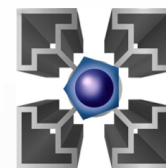

*From precise pencil
grinders and die grinders
to large vertical grinders,*

Eagle Group has the right tool for your application. With a wide variety of horsepower ratings, RPMs, guards, and collet sizes, Eagle Group grinders excel in many applications, including blending, smoothing, cleaning, weld preparation, and deburring in maintenance, fabrication, and construction markets.



5I-03302 1/4" Steel Die Grinders

INDUSTRIAL DUTY



0.3 HP

5I-03302F

FRONT EXHAUST



0.3 HP

- Lightweight design with smooth performance
- Erickson collet precisely grips attachments resulting in minimal runout
- Safety lockout throttle lever prevents accidental start

5000 1/8" Pencil Grinder

GENERAL DUTY

- Excellent for blending/finishing work
- High-speed precision
- Complete with air hose, exhaust hose, and integral silencer



0.1 HP

5000

Application	General
Housing	Aluminum
Collet Size	1/8"
Approx. Power (hp)	0.1
Approx. Speed (rpm)	54,000
Throttle Type	Twist
Exhaust	Rear hose
Weight	0.6 lb / 0.3 kg
Length	5.3" / 133 mm
Air Usage (cfm)	6
Air Inlet	1/4"

5001 1/4" Steel Die Grinder

- All steel housing
- Built-in regulator
- 1/8" collet available

GENERAL DUTY



0.33 HP

5110 1/4" Aluminum Mini Die Grinder

- Good for light weld grinding, polishing, and breaking sharp edges
- Air regulator allows operator to control speed

GENERAL DUTY



0.38 HP

5002C 1/4" Aluminum Die Grinder

- Compact and lightweight
- All ball-bearing construction
- Rib textured handle provides firm grip
- For blending, smoothing, and porting
- 1/8" collet available (part #32046-31-02)

GENERAL DUTY



0.33 HP

Model	Application	Housing	Collet Size	Approx. Power (hp)	Approx. Speed (rpm)	Throttle Type	Exhaust	Weight		Length		Air Usage (cfm)	Air Inlet
								lb	kg	in	mm		
5I-03302	Industrial	Steel	1/4"	0.3	30,000	Lever	Rear	1	0.45	6.5	165	20	1/4"
5I-03302F	Industrial	Steel	1/4"	0.3	30,000	Lever	Front	1	0.45	6.5	165	20	1/4"
5001	General	Steel	1/4"	0.33	18,000	Lever	Front	1.3	0.6	6.5	165	14	1/4"
5002C	General	Aluminum	1/4"	0.33	22,000	Lever	Rear	1.2	0.5	6.9	175	14	1/4"
5110	General	Aluminum	1/4"	0.38	25,000	Lever	Rear	0.8	0.4	4.8	122	14	1/4"

5201EC 5200EC 1/4" Composite Die Grinders

GENERAL DUTY

Mini Grinder



0.5 HP



0.75 HP

- Lightweight and durable
- Ergonomic composite housing with a soft comfortable grip
- For blending, smoothing, and sanding
- Less noise, vibration, and thermal transfer than aluminum tools

5I-04252 5I-06222 1/4" Composite Die Grinders

INDUSTRIAL DUTY



0.4 HP



0.6 HP

- Lightweight design with smooth performance
- Erickson collet precisely grips attachments resulting in minimal runout
- Safety lockout throttle lever prevents accidental tool start

Model	Application	Housing	Collet Size	Approx. Power (hp)	Approx. Speed (rpm)	Throttle Type	Exhaust	Weight		Length		Air Usage (cfm)	Air Inlet
								lb	kg	in	mm		
5201EC	General	Composite	1/4"	0.5	25,000	Lever	Rear	0.8	0.36	6.25	159	12	1/4"
5200EC	General	Composite	1/4"	0.75	22,000	Lever	Rear	1.3	0.59	6.75	171	14	1/4"
5I-04252	Industrial	Composite	1/4"	0.4	25,000	Lever	Rear	1	0.46	7	179	25	1/4"
5I-06222	Industrial	Composite	1/4"	0.6	22,000	Lever	Rear	1.58	0.72	7.8	198	30	1/4"

1/4" HEAVY-DUTY STEEL DIE GRINDERS

5I-06251

5I-10202

INDUSTRIAL DUTY

Compact



0.6 HP



1.0 HP

- Heavy-duty steel housing
- Erickson collet precisely grips attachments for long-lasting, minimal runout
- Safety lockout throttle lever prevents accidental tool start
- 5I-10202: Governed air motor for safe use and maximum power and speed under load

Model	Application	Housing	Collet Size	Approx. Power (hp)	Approx. Speed (rpm)	Throttle Type	Exhaust	Weight		Length		Air Usage (cfm)	Air Inlet
								lb	kg	in	mm		
5I-06251	Industrial	Steel	1/4"	0.6	25,000	Lever	Rear	1.45	0.66	6.5	165	19	1/4"
5I-10202	Industrial	Steel	1/4"	1.0	20,000	Lever	Rear	2.82	1.28	7.9	201	35	3/8"

5206EC (3") / 5207EC (5") 1/4" Composite Die Grinders, 3" & 5" Extended

GENERAL DUTY



0.6 HP



0.6 HP

- Lightweight and durable
- Extended length for hard-to-reach areas
- Ergonomic composite housing with a soft comfortable grip
- For blending, smoothing, and porting
- Less noise, vibration, and thermal transfer than aluminum tools

1/4" COMPOSITE HEAVY-DUTY DIE GRINDERS, 5" EXTENDED

5I-04252X

5I-06202X

INDUSTRIAL DUTY



0.4 HP



0.6 HP

- Lightweight design with smooth performance
- Erickson collet precisely grips attachments resulting in minimal runout
- Safety lockout throttle lever prevents accidental start

5116 1/4" Aluminum Die Grinder, 6" Extended

GENERAL DUTY

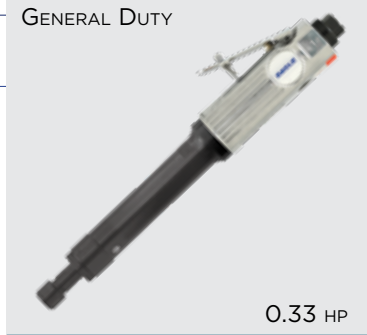

0.33 HP

- All ball-bearing construction
- Extended length for hard-to-reach areas
- Rib textured handle provides firm grip
- For blending, smoothing, and porting

5I-10202X 1/4" Steel Die Grinder, 6" Extended

INDUSTRIAL DUTY



1.0 HP

- 1/4" Erickson collet precisely grips attachments for long-lasting, minimal runout
- Robust safety lever and all-steel body construction
- Double bearing supported spindle
- Full 1 HP governed air motor for safe use and maximum power and speed under load

Model	Application	Housing	Extension	Collet Size	Approx. Power (hp)	Approx. Speed (rpm)	Throttle Type	Exhaust	Weight		Length		Air Usage (cfm)	Air Inlet
									lb	kg	in	mm		
5206EC	General	Composite	3"	1/4"	0.6	25,000	Lever	Rear	1.43	0.65	9.25	235	12	1/4"
5207EC	General	Composite	5"	1/4"	0.6	25,000	Lever	Rear	1.45	0.66	11.25	286	12	1/4"
5I-04252X	Industrial	Composite	5"	1/4"	0.4	25,000	Lever	Rear	1.4	3.08	12.2	309	25	1/4"
5I-06202X	Industrial	Composite	5"	1/4"	0.6	20,000	Lever	Rear	2.31	1.05	13.03	331	30	1/4"
5116	General	Aluminum	6"	1/4"	0.33	22,000	Lever	Rear	2.75	1.2	13.0	305	14	1/4"
5I-10202X	Industrial	Steel	6"	1/4"	1	20,000	Lever	Rear	4.5	2	14.5	368	35	3/8"

ANGLE DIE GRINDERS

5001C
1/4" Aluminum
Angle Die Grinder

5003C
1/4" Aluminum
Angle Die Grinder

GENERAL DUTY



Front
Exhaust



0.33 HP

- Compact lightweight design
- Ball-bearing construction
- For sanding, deburring, and polishing
- Right angle provides easy access
- 5001C: front exhaust

5202EC
1/4" Composite Angle
Die Grinder, 90°

5203EC
1/4" Composite Angle
Die Grinder, 105°

GENERAL DUTY



0.6 HP



0.6 HP

- Lightweight and durable
- Ergonomic composite housing with a soft comfortable grip
- Less noise, vibration, and thermal transfer than aluminum tools
- Right angle provides easy access
- For sanding, polishing, deburring, and porting

5A-04122 / 5A-04202
1/4" Composite Angle Die Grinder

- Lightweight design with smooth performance
- Erickson collet precisely grips attachments resulting in minimal runout
- Safety lockout throttle lever prevents accidental start



INDUSTRIAL DUTY

0.4 HP

Model	Application	Housing	Collet Size	Approx. Power (hp)	Approx. Speed (rpm)	Throttle Type	Exhaust	Weight		Length		Air Usage (cfm)	Air Inlet
								lb	kg	in	mm		
5001C	General	Aluminum	1/4"	0.33	20,000	Lever	Front	1.1	0.5	5	127	14	1/4"
5003C	General	Aluminum	1/4"	0.33	20,000	Lever	Rear	1.0	0.5	6.3	159	14	1/4"
5A-04122	Industrial	Composite	1/4"	0.4	12,000	Lever	Rear	1.3	0.59	7.2	182	20	1/4"
5A-04202	Industrial	Composite	1/4"	0.4	20,000	Lever	Rear	1.3	0.59	7.2	182	19	1/4"
5202EC 5203EC	General	Composite	1/4"	0.6	20,000	Lever	Rear	1.1	0.55	6.25	159	12	1/4"

5A-0514-2 2" Steel Angle Grinder

- Robust, steel design for harsh use environments
- 2" angle head designed for limited access and ease of maneuverability
- Adjustable guard rotation for best protection

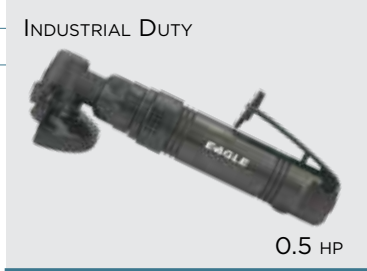

5205-2EC 3" Composite Angle Grinder, 105°

- Ergonomic and safe use design
- 105° angled head design provides improved sight lines and spark angle
- Tight access use
- 1/16" to 1/4" wheel capability



5006 (4") / 5007 (5") 4" & 5" Aluminum Angle Grinders

- Governed motor
- 5/8"-11 adapter included
- Uses Type 27 wheels, abrasive discs
- Spiral bevel gearing for extended life, low vibration
- For weld prep, smoothing, rust removal, and deburring
- Lightweight aluminum alloy housing



5194EC (4") / 5195EC (4.5") / 5196EC (5") 4", 4.5", 5" Composite Angle Grinders

- Swivel guard adjustable in nine steps
- Composite body, spindle lock, rear exhaust, quiet operation
- Reversible side handle
- Governed motor



	5194EC	5195EC	5196EC
Application	Industrial		
Wheel Capacity	4"	4.5"	5"
Housing	Composite		
Spindle	3/8"-24	5/8"-11	5/8"-11
Approx. Power (hp)	1.3		
Approx. Speed (rpm)	12,000		
Throttle Type	Lever		
Exhaust	Rear		
Weight	3.8 lb / 1.72 kg		
Length	9.6" / 244 mm		
Air Usage (cfm)	25		
Air Inlet	1/4"		

ACCESSORIES

8101 Ergo Handle

- Dramatically reduces vibration
- For models 5194EC, 5195EC, and 5196EC



8102 / 8103 Quick Nut

- Eliminates spanner wrench
- #8102 for 5/8"-11 spindle (5195EC & 5196EC)
- #8103 for 3/8"-24 spindle (5194EC)



Model	Application	Housing	Wheel Capacity	Spindle	Approx. Power (hp)	Approx. Speed (rpm)	Throttle Type	Exhaust	Weight		Length		Air Usage (cfm)	Air Inlet
									lb	kg	in	mm		
5A-0514-2	Industrial	Steel	2"	3/8"-24	0.5	14,000	Lever	Side	3	1.4	8.5	216	15	1/4"
5205-2EC	General	Composite	3"	3/8" shaft	0.6	15,000	Lever	Rear	1.5	0.68	8.25	210	12	1/4"
5006	General	Aluminum	4"	3/8"-24*	0.6	11,000	Lever	Front right	4	1.8	9.5	241	18	1/4"
5007	General	Aluminum	5"	3/8"-24*	0.6	11,000	Lever	Front right	4.3	1.8	9.5	241	18	1/4"

* 5/8"-11 adapter included

ANGLE GRINDERS



5104 (4") / 5105 (5") 4" & 5" Sandcast Aluminum Angle Grinders

- All steel internal parts
- Four-step heat treat process
- Sandcast aluminum housing
- Uses Type 27 wheels and abrasive discs

5008 7" Aluminum Angle Grinder

- Governed motor
- Aluminum alloy housing
- Uses 7/8" arbor wheels only
- Spiral bevel gear angle head for long tool life
- For cleaning, deburring, notching, and grinding



GAB41-A60-DW 9" Sandcast Aluminum Angle Grinder

PREMIER QUALITY

- 60-100% faster material removal than other grinders on the market
- Patented low-friction air motor design
- Less wear on air motor parts
- Less susceptible to poor air quality
- Higher horsepower than competitors



5A-1676-7 7" Sandcast Aluminum Angle Grinder

- All steel internal parts
- Four-step heat treat process
- Sandcast aluminum housing
- Uses Type 27 wheels and abrasive discs



GAB41-A60-DW	
Application	Premier Quality
Wheel Capacity	9"
Housing	Sandcast aluminum
Spindle	5/8"-11
Approx. Power (hp)	3.75
Approx. Speed (rpm)	6,000
Throttle Type	Lever
Exhaust	Side
Weight	7.5 lb / 3.4 kg
Length	13.5" / 343 mm
Air Usage (cfm)	38 static / 105 dynamic*
Air Inlet	1/2"

* CFM air consumption readings are static/dynamic at 90 psi

Model	Application	Housing	Wheel Capacity	Spindle	Approx. Power (hp)	Approx. Speed (rpm)	Throttle Type	Exhaust	Weight		Length		Air Usage (cfm)	Air Inlet
									lb	kg	in	mm		
5104	Industrial	Sandcast aluminum	4"	3/8"-24	1	13,500	Pushbutton/lever	Front right	4.4	2	8.3	211	34	1/4"
5105	Industrial	Sandcast aluminum	5"	5/8"-11	1	10,800	Pushbutton/lever	Front right	4.4	2	8.3	211	34	1/4"
5008	General	Aluminum	7"	5/8"-11	1.1	7,000	Pushbutton/lever	Bottom	7.9	3.2	13.5	343	34	3/4"
5A-1676-7	Industrial	Sandcast aluminum	7"	5/8"-11	1.6	7,600	Lever	Front right	6.6	3	11.8	300	56	3/8"

GDB31-E18-CE
2.7 HP Composite/Steel Horizontal Grinder

GDB31-E18-CW
2.7 HP Composite/Steel Horizontal Grinder

PREMIER QUALITY



- 60 - 100% faster material removal than other grinders on the market
- Patented low-friction air motor design
- Less wear on air motor parts
- Less susceptible to poor air quality
- Higher horsepower than competitors

	GDB31-E18-CE	GDB31-E18-CW
Application	Premier Quality	
Housing	Composite/steel	
Collet Size	1/4"	NA
Spindle Type	NA	5/8"-11
Approx. Power (hp)	2.7	
Approx. Speed (rpm)	18,000	
Throttle Type	Lever	
Exhaust	Rear	
Weight	4.8 lb / 2.2 kg	4.9 lb / 2.2 kg
Length	15.1" / 384 mm	14.6" / 371 mm
Air Usage (cfm)	34 static / 63 dynamic*	
Air Inlet	1/2"	

* CFM air consumption readings are static/dynamic at 90 psi

Introducing the PREMIER Series of Pneumatic Grinders for High-Horsepower Metal Removal

Advanced patented air motor design creates the optimum combination of power-to-weight and "pedal-to-the-metal" longevity matched to the environment in which it's used. *Premier* provides the best for high-horsepower working environments with the GTB Turbine grinder series and GAB/GDB/GVB Vaned Bearing Motor grinder series. One is lube-free by design, the other by choice.

GTB Series
Turbine Motor Design



- 60 - 100% faster material removal than other grinders on the market
- Lower sensitivity to air-hose pressure variation
- Lower vibration levels
- Oil-free operation ensures a clean surface and is environmentally friendly
- Ergonomic shape for easy control and less operator fatigue
- Low maintenance cost

GAB / GDB / GVB Series
Vaned Bearing Motor Design



- Rotating air motor cylinder and end plates create minimal wear on air motor vanes, cylinder, and plates for fewer repairs and less downtime
- Drag-free motor speed increases working power, both under load and over time for maximum productivity

TURBINE GRINDERS

PREMIER QUALITY TURBINE GRINDERS

5" GRINDER: GTB31-A12-DW

6" GRINDER: GTB41-A60-DW-6

7" GRINDER: GTB41-A85-DW

9" GRINDER: GTB41-A60-DW



- 60-100% faster material removal than other grinders on the market
- Twice the horsepower of vaned motors
- Lower noise level than vaned motors
- No repair and replacement of common air motor parts
- Oil-free operation required

Model	Application	Housing	Wheel Capacity	Spindle	Approx. Power (hp)	Approx. Speed (rpm)	Throttle Type	Exhaust	Weight		Length		Air Usage (cfm)*	Air Inlet
									lb	kg	in	mm		
GTB31-A12-DW	Premier	Sandcast aluminum	5"	5/8"-11	4.6	12,000	Lever	Side	5.7	2.6	13.5	343	30 / 95	1/2"
GTB41-A60-DW-6	Premier	Sandcast aluminum	6"	5/8"-11	6.5	6,000	Lever	Side	7	3.2	13.5	343	38 / 131	1/2"
GTB41-A85-DW	Premier	Sandcast aluminum	7"	5/8"-11	6.5	8,500	Lever	Side	7	3.2	13.5	343	38 / 131	1/2"
GTB41-A60-DW	Premier	Sandcast aluminum	9"	5/8"-11	6.5	6,000	Lever	Side	7	3.2	13.5	343	38 / 131	1/2"

* CFM air consumption readings are static/dynamic at 90 psi



>> GRINDERS

VERTICAL GRINDERS

5040-6 (6") / 5040 (7") / 5040-9 (9") 6" / 7" / 9" Aluminum Vertical Grinders

INDUSTRIAL DUTY



5040 / 5040-9

- 3 HP governed motor
- Durable aluminum housing
- Safety throttle

	5040-6	5040	5040-9
Application	Industrial		
Housing	Aluminum		
Wheel Capacity	6"	7"	9"
Spindle	5/8"-11		
Approx. Power (hp)	3.0		
Approx. Speed (rpm)	6,000		
Throttle Type	Pushbutton / lever		
Exhaust	Side/directional		
Weight	7.7 lb / 3.5 kg		
Length	12" / 305 mm		
Air Usage (cfm)	49		
Air Inlet	1/2"		

5040-7G
7" GUARD



5040-6CG
6" CUP GUARD



5040-9G
9" GUARD



6" / 7" / 9" PREMIER QUALITY VERTICAL GRINDERS

GVB51P-V60-DW-6 6" / GVB51P-V85-DW 7" / GVB51P-V60-DW 9"



- 60 - 100% faster material removal than other grinders on the market
- Patented low-friction air motor design
- Less wear on air motor parts
- Less susceptible to poor air quality
- Higher horsepower than competitors

	GVB51P-V60-DW-6	GVB51P-V85-DW	GVB51P-V60-DW
Application	Premier Quality		
Housing	Sandcast aluminum		
Wheel Capacity	6"	7"	9"
Spindle	5/8"-11		
Approx. Power (hp)	4.3		
Approx. Speed (rpm)	6,000	8,500	6,000
Throttle Type	Lever		
Exhaust	Side		
Weight	10.8 lb / 4.9 kg		
Length	10.5" / 267 mm		
Air Usage (cfm)	35 static / 110 dynamic*		
Air Inlet	1/2"		
* CFM air consumption readings are static/dynamic at 90 psi			

SANDERS SANDERS

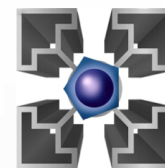

*A perfect mix
of dependability,
features, and value,*

Eagle Group sanders and
polishers are ideal for a wide
range of finishing and refinishing
applications, including auto paint &
body shops, wood working shops,
fiberglass finishers, and general industry.

2" COMPOSITE SERIES ANGLE SANDERS

- Lightweight and durable
- Ergonomic composite housing with a soft comfortable grip
- Less noise, vibration, and thermal transfer than aluminum tools

6133EC Angle Sander, 90°

GENERAL DUTY



15,000 RPM

6134EC Angle Sander, 105°

GENERAL DUTY



6115EC Angle Orbital Sander, 105°

GENERAL DUTY



15,000 RPM

- Pad Size: 2" Diameter, M6 x 1.0 thread, yellow polyurethane foam pad, hooked Velcro face
- Orbital Capacity: 0.2" / 3.0 mm

- 6133EC and 6134EC with roll lock abrasive holder

Model	Application	Housing	Sanding Disc	Pad Size	Spindle	Approx. Power (hp)	Approx. Speed (rpm)	Weight		Length		Air Usage (cfm)	Air Inlet
								lb	kg	in	mm		
6133EC	General	Composite	2"	1.75"	1/4"-20	0.25	15,000	1.05	0.48	6.75	171	12	1/4"
6134EC	General	Composite	2"	1.75"	1/4"-20	0.25	15,000	1.05	0.48	6.75	171	12	1/4"
6115EC	General	Composite	2"	2"	1/4"-20	0.3	15,000	1.36	0.62	6.75	171	12	1/4"

6012 7" Aluminum Angle Sander

- Powerful 1 hp motor
- Dead handle mounts either side
- Hardened and ground spiral bevel gears for long life
- For heavy rust removal, sanding, and shaping of filler patches



6507 7" Aluminum Angle Polisher

- Built-in power regulator
- Dead handle for easy control
- Ideal for buffing and polishing paint and metal to a professional finish

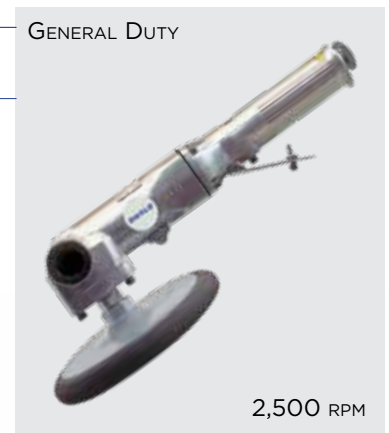

Model	Application	Housing	Sanding Disc	Pad Size	Spindle	Approx. Power (hp)	Approx. Speed (rpm)	Weight		Length		Air Usage (cfm)	Air Inlet
								lb	kg	in	mm		
6012	General	Aluminum	7"	7"	5/8"-11	1	4,500	6	2.7	15	381	19	1/4"
6507	General	Aluminum	7"	7"	5/8"-11	0.25	2,500	6.5	2.9	18	457	12	1/4"

ORBITAL & JITTERBUG SANDERS

6905EC (5") / 6906EC (6")

5" & 6" Composite Random Orbital Sanders

INDUSTRIAL DUTY



12,000 RPM

- Vibration absorbing grip
- High power and lightweight
- PSA pad type
- Orbital action assures swirl-free finish
- For touch-up, feather-edging, sanding, pre-paint preparation

6905EC **6906EC**

Application	Industrial	
Housing	Composite	
Pad Size	5"	6"
Spindle	5/16"-24	
Orbit	3/16" pattern	
Approx. Power (hp)	0.25	
Approx. Speed (rpm)	12,000	
Weight	2 lb / 0.9 kg	
Length	6.9" / 175 mm	
Air Usage (cfm)	15	
Air Inlet	1/4"	

6005

6" Aluminum Dual-Action Orbital Sander

- Dual action
- Built-in regulator
- Insulated grip
- Lightweight all aluminum body construction
- For touch-up, feather-edging, sanding, and pre-paint preparation

GENERAL DUTY



10,000 RPM

6009

Jitterbug Sander

- Durable construction
- For wet and dry sanding
- For wood, metal, or plastic finishing and fiberglass

GENERAL DUTY



8,000 RPM

Model	Application	Housing	Pad Size	Spindle	Orbit	Approx. Power (hp)	Approx. Speed (rpm)		Weight		Length		Air Usage (cfm)	Air Inlet
									lb	kg	in	mm		
6005	General	Aluminum	6"	5/16"-24	5/16" pattern	0.25	10,000		5.2	2.1	12	305	16	1/4"
6009	General	Aluminum	3.5 x 7.75 in 89 x 197 mm	—	—	0.25	8,000		4.3	2	8	203	15	1/4"

HIGH-SPEED, BOARD, & BELT SANDERS

6113 3" - 5" High-Speed Sander

- Lightweight, compact design
- Includes 3" & 5" backing pads
- Built-in regulator to control speed
- For paint removal, shaping filler patches, weld smoothing, rust removal



6017 Two-Piston Board Sander

- Two handle design
- Smooth feathers; dual pistons provide efficient power and prevent stalling
- For all types of surface preparation and rapid removal of material from large areas

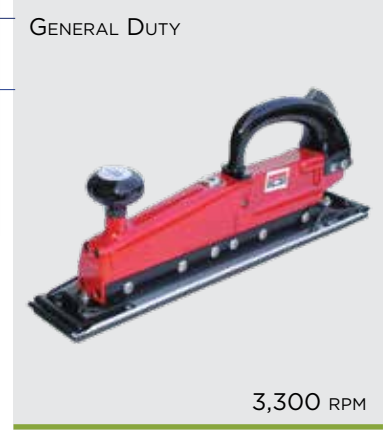

Model	Application	Housing	Pad Size	Spindle	Approx. Power (hp)	Approx. Speed (rpm)	Weight		Length		Air Usage (cfm)	Air Inlet
							lb	kg	in	mm		
6113	General	Aluminum	3" / 5"	3/8"	0.25	18,000	2.4	1.1	4.6	117	19	1/4"
6017	General	Aluminum	2.5 x 15.75 in 63 x 400 mm	—	0.75	3,300	6.87	3	16	406	9	1/4"

ALUMINUM BELT SANDERS

- Best for sanding confined areas and curved surfaces
- Adjustable sanding belt rotates to allow easy handling
- Quick-change belt replacement

Model	Application	Housing	Belt Size		Approx. Power (hp)	Approx. Speed (rpm)	Weight		Length		Air Usage (cfm)	Air Inlet
			in	mm			lb	kg	in	mm		
6114	General	Aluminum	3/8 x 13	10 x 305	0.33	16,000	1.7	0.8	10.5	267	14	1/4"
6115	General	Aluminum	1/2 x 24	13 x 610	0.33	16,000	1.7	0.8	23.5	597	14	1/4"
6116	General	Aluminum	3/4 x 20.5	20 x 520	0.4	16,000	3.1	1.4	11.9	302	18	1/4"

6114

6115

6116



IMPACT WRENCHES IMPACT WRENCHES

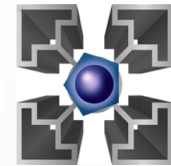

From light-duty plant maintenance to heavy-duty industrial steel applications,

Eagle Group impact wrenches are available in single hammer, twin hammer, and pin clutch types.

IMPACT WRENCH CLUTCH INFORMATION

Eagle Group's Impact Wrenches are available with various clutch configurations. Choosing the correct clutch depends on application requirements such as weight, vibration, durability, ease of maintenance, torque, and power.



Single Hammer

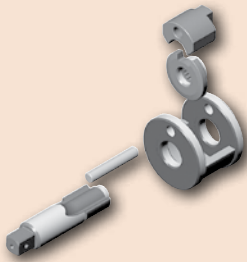

The Single Hammer design is proven and cost effective. It delivers a high torque-to-weight ratio.



Uses

- Standard assembly
- Automotive repair
- Light industrial use

Twin Hammer

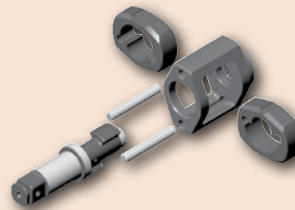

The Twin Hammer design provides a reliable system producing torque quickly with two forged hammers.



Uses

- Industrial maintenance
- Tire service

Pin Clutch

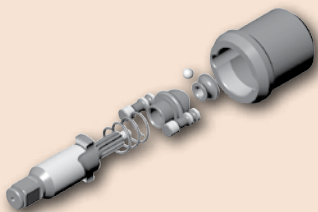

The Pin Clutch design provides rapid delivery of torque and high power-to-weight ratio.



Uses

- Maintenance
- Light assembly
- Hard joints

Swing Hammer

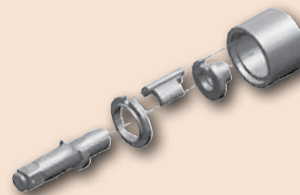

The Swing Hammer Clutch is a simple, effective design that provides rapid delivery of torque.



Uses

- Standard assembly applications
- Maintenance
- Hard joints

3/8" - 1/2" IMPACT WRENCHES

2010

3/8" Single Hammer Diecast Aluminum Impact Wrench

- Single hammer design
- Air inlet swivels 360° for easy maneuvering
- For bench work, carburetors, ignitions, body panels, transmissions, fender struts, oil pans, and small engine work
- Butterfly throttle allows one-hand directional changes

GENERAL DUTY



WORKING TORQUE: 75 FT-LB

2150

3/8" Twin Hammer Steel Impact Wrench

- Twin hammer design
- Steel clutch housing protects hammer mechanism
- Fast cycle times
- Long life
- For general industrial use

INDUSTRIAL DUTY



WORKING TORQUE: 145 FT-LB

GENERAL DUTY



2260L

WORKING TORQUE: 260 FT-LB

2260L

1/2" Twin Pin Composite Impact Wrench

- Engineered for the after-market automotive industry
- Pin clutch design to quickly deliver torque
- 2-1/2" extended anvil

2263EC / 2263PEC

1/2" Twin Hammer Composite Impact Wrenches

INDUSTRIAL DUTY

2263EC



WORKING TORQUE: 295 FT-LB

2263PEC



Pin Type Anvil

- Twin hammer design
- Swivel air inlet fitting
- Large easy-to-use forward reverse switch
- Bottom grease fitting

Model	Application	Housing	Hammer	Drive Size	Approx. Speed (rpm)	Torque Range		Max Torque		Weight		Length		Air Usage (cfm)	Air Inlet
						ft-lb	Nm	ft-lb	Nm	lb	kg	in	mm		
3/8" Wrenches															
2010	General	Aluminum	Single	3/8"	10,000	11 - 75	15 - 102	92	125	2.8	1.3	6.4	163	13	1/4"
2150	Industrial	Aluminum	Twin	3/8"	10,000	100 - 145	136 - 197	199	270	3.3	1.5	6	152	13	1/4"
1/2" Wrenches															
2260L	General	Composite	Twin pin	1/2"	7,500	114 - 260	154 - 352	302	409	6.15	2.8	7.5	194	12	1/4"
2263EC 2263PEC	Industrial	Composite	Twin	1/2"	7,800	210 - 295	284 - 400	333	452	4.5	2	8.2	208	19	1/4"

2225 / 2225L

1/2" Twin Hammer Diecast Aluminum Impact Wrenches

GENERAL DUTY



WORKING TORQUE: 328 FT-LB

- Diecast aluminum housing for durability
- Twin hammer design
- Compact size for tight access
- Handle exit exhaust
- 2225 with standard anvil
- 2225L with 2-3/4" extended anvil

1/2" Twin Hammer Composite Impact Wrenches

2240

2240PEC

INDUSTRIAL DUTY



WORKING TORQUE: 410 FT-LB

- Composite and lightweight housing
- Twin hammer design
- Swivel air inlet fitting
- Unique motor set design eliminates power loss
- Noise-reducing exhaust design for quiet operation

2004

3/4" Single Hammer Diecast Aluminum Impact Wrench

GENERAL DUTY



WORKING TORQUE: 550 FT-LB

- Single hammer design
- Built-in regulator
- Available with extended anvil

Model	Application	Housing	Hammer	Drive Size	Approx. Speed (rpm)	Torque Range		Max Torque		Weight		Length		Air Usage (cfm)	Air Inlet
						ft-lb	Nm	ft-lb	Nm	lb	kg	in	mm		
1/2" Wrenches															
2225 2225L	General	Diecast aluminum	Twin	1/2"	8,000	190 - 328	257 - 445	365	495	5.6	2.5	7.25	184	15	1/4"
2240 2240PEC	Industrial	Composite	Twin	1/2"	8,000	100 - 410	135 - 550	450	600	4.9	2.3	8.3	208	18	1/4"
3/4" Wrench															
2004	General	Diecast aluminum	Single	3/4"	5,000	145 - 500	196 - 746	600	815	10.5	4.8	9.5	241	28	3/8"

3/4" - 1" IMPACT WRENCHES

2P-155034

3/4" Twin Hammer Composite Impact Wrench

INDUSTRIAL DUTY



WORKING TORQUE: 1,000 FT-LB

2P-15501

1" Twin Hammer Composite Impact Wrench



WORKING TORQUE: 1,750 FT-LB

- Extremely lightweight with ergonomic handle configuration
- Proportional trigger for operator control
- Recessed torque output selector in CW direction: Low-Mid-High
- Reverse (CCW) always delivered with maximum power
- Swiveling 360° air inlet
- Reliable 7-vane air motor for consistent power delivery

2450 / 2450L

1" Twin Hammer Sandcast Aluminum Impact Wrenches

INDUSTRIAL DUTY

2450



2450L



WORKING TORQUE: 1,450 FT-LB

- Twin hammer design
- Smooth power in a compact, lightweight design
- 2450 with standard 3" anvil
- 2450L with 6" extended anvil

INDUSTRIAL DUTY



WORKING TORQUE: 1,300 FT-LB

2463

1" Twin Hammer Steel Impact Wrench, Extended

- Twin hammer design
- Steel clutch housing protects hammer mechanism
- For tire changing on trucks and buses

Model	Application	Housing	Hammer	Drive Size	Approx. Speed (rpm)	Torque Range		Max Torque		Weight		Length		Air Usage (cfm)	Air Inlet
						ft-lb	Nm	ft-lb	Nm	lb	kg	in	mm		
3/4" Wrenches															
2P-155034	Industrial	Composite	Twin	3/4"	6,000	625 - 1,250	850 - 1,690	1,400	1,890	6.7	3.05	8.2	209	7	3/8"
1" Wrenches															
2P-15501	Industrial	Composite	Twin	1"	5,000	500 - 2,000	678 - 2,710	2,250	3,050	13	5.9	10	256	12	1/2"
2450 2450L	Industrial	Sandcast aluminum	Twin	1"	6,000	940 - 1,450	1,274 - 1,965	1,600	2,169	19	8.5	19.5	495	26	1/2"
2463	Industrial	Steel	Twin	1"	3,900	670 - 1,300	908 - 1,760	1,600	2,169	20.2	9	22	559	26	1/2"

1"- 1-1/2" IMPACT WRENCHES

IMPACT WRENCHES

2403L 1" Twin Hammer Composite Impact Wrench, Extended

INDUSTRIAL DUTY



WORKING TORQUE: 1,875 FT-LB

- Composite housing reduces weight
- Extended anvil
- Twin hammer design
- Swivel exhaust

2485L 1" Swing Hammer Sandcast Aluminum Impact Wrench, Extended

INDUSTRIAL DUTY



WORKING TORQUE: 1,875 FT-LB

- Swing-hammer clutch design for low vibration
- Extended anvil for optimal access on deep wheels and applications

2S-290015 1-1/2" Pinless Lightweight Heavy-Duty Impact Wrench

INDUSTRIAL DUTY



WORKING TORQUE: 3,000 FT-LB

- High power-to-weight ratio
- Inside trigger design for safety
- Reversible D handle for ergonomic handling of the tool by right or left handed operators
- Efficient air motor design for best use of air pressure and volume on most job sites

Model	Application	Housing	Hammer	Drive Size	Approx. Speed (rpm)	Torque Range		Max Torque		Weight		Length		Air Usage (cfm)	Air Inlet
						ft-lb	Nm	ft-lb	Nm	lb	kg	in	mm		
1" Wrenches															
2403L	Industrial	Composite	Twin	1"	4,000	1,250 - 1,875	1,695 - 2,550	2,000	2,825	21.3	9.7	23	584	25	1/2"
2485L	Industrial	Sandcast aluminum	Swing	1"	4,000	833 - 1,875	1,130 - 2,542	2,290	3,100	28	12.7	19	482	30	1/2"
1-1/2" Wrenches															
2S-290015	Industrial	Aluminum	Swing	1-1/2"	4,000	750 - 3,000	1,016 - 4,050	3,300	4,455	33.7	15.3	24.4	620	12	1/2"

RATCHET WRENCHES RATCHET WRENCHES

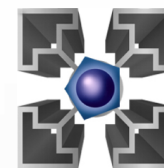

If you need to reach small bolts in tight places,
Eagle Group's ergonomic ratchet wrenches are the tools you need. These wrenches are ideally suited for light and medium duty industrial and maintenance applications, including body shop work, water pumps, radiators, spark plugs, air conditioning, and light assembly.

3115 1/4" Ratchet Wrench

GENERAL DUTY



WORKING TORQUE: 18 FT-LB

- Rear exhaust with silencer
- Extended ratchet housing for greater reach
- For smaller fasteners

GENERAL DUTY



WORKING TORQUE: 55 FT-LB

3105 1/2" Ratchet Wrench

- Excellent for general purpose use
- Improved gear head extends life
- Powerful for tough jobs

3320 1/2" Ratchet Wrench

INDUSTRIAL DUTY



WORKING TORQUE: 80 FT-LB

- Excellent for general purpose use
- Improved gear head extends life
- Powerful for tough jobs
- Patented head design for increased durability

3/8" RATCHET WRENCHES

3100

GENERAL DUTY



WORKING TORQUE: 24 FT-LB

- Ball & needle bearing construction for long life
- Internal ring gear with three planetary gears

3205

GENERAL DUTY



WORKING TORQUE: 30 FT-LB

- Composite grip for increased operator comfort
- Built-in grease fitting for lubrication ease

3220

INDUSTRIAL DUTY



WORKING TORQUE: 80 FT-LB

- Composite grip for increased operator comfort
- Built-in grease fitting for lubrication ease
- Patented head design for increased durability

Model	Application	Housing	Drive Size	Approx. Speed (rpm)	Approx. Torque		Weight		Length		Air Usage (cfm)	Air Inlet
					ft-lb	Nm	lb	kg	in	mm		
3115	General	Aluminum/steel	1/4"	230	18	24	1.4	0.6	8	203	10	1/4"
3100	General	Aluminum/steel	3/8"	160	24	33	2.6	1.2	10.5	267	16	1/4"
3205	General	Aluminum/steel	3/8"	160	30	40	2.5	1.1	10.5	267	18	1/4"
3220	Industrial	Aluminum/steel	3/8"	280	80	109	2.7	1.2	10.9	277	4	1/4"
3105	General	Aluminum/steel	1/2"	150	55	74	3.1	1.4	14.5	368	21	1/4"
3320	Industrial	Aluminum/steel	1/2"	280	80	109	2.7	1.2	10.9	277	4	1/4"

PULSE TOOLS

PULSE TOOLS

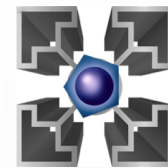

Providing accurate torque control without the high-maintenance cost of impact wrenches,

Eagle Group's pulse tools provide smooth, controlled torque to hard-draw and medium-draw applications. Lighter and quieter than impact wrenches, Eagle Group pulse tools are ideally suited for general assembly and woodworking.

1/4" HEX Q.C. & 3/8" SQ. DR. NON SHUT-OFF PULSE TOOLS

9020D
1/4" Quick Change
Pistol Pulse Driver

GENERAL DUTY



FOR SCREWS
TORQUE RANGE: 10 - 19 FT-LB

9025D
1/4" Quick Change
Pistol Pulse Driver



FOR SCREWS
TORQUE RANGE: 15 - 20 FT-LB

9025
3/8" Pistol Pulse
Driver



FOR BOLTS AND NUTS
TORQUE RANGE: 17 - 20 FT-LB

- Quiet operation and low vibration
- No torque reaction even at high torque
- Lightweight
- Accurate torque means no stripped threads or broken screws
- Easy maintenance with few parts to replace

Model	Application	Housing	Drive Size/ Anvil	Approx. Speed (rpm)	Torque Range		Weight		Length		Air Usage (cfm)	Air Inlet
					ft-lb	Nm	lb	kg	in	mm		
9020D	General	Aluminum	1/4" QC	7,000	10 - 19	13 - 25	2	0.9	6	15.2	11	1/4"
9025D	General	Aluminum	1/4" QC	7,000	15 - 20	20 - 27	2.1	1	6.6	16.7	16	1/4"
9025	General	Aluminum	3/8"	7,000	17 - 22	22 - 29	2.1	1	6.4	16.2	16	1/4"

PULSE TOOLS

ASSEMBLY TOOLS

ASSEMBLY TOOLS

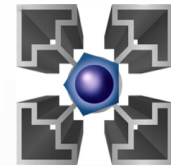

*Available in a variety
of clutch styles and
torque ranges,*

Eagle Group's ergonomic
screwdrivers are the go-to tools for
furniture, woodworking, motor home,
boat, RV, van conversion, and
appliance industries.

ASSEMBLY TOOL CLUTCH INFORMATION

The variety of Eagle Group's assembly clutch tools ensures that you match the right tool with your application's requirements for precision, speed, power, torque, type of draw, or screw size.



Adjustable Clutch



The adjustable clutch ratchets upon reaching torque. It provides general torque control.

Uses

- General assembly
- Woodworking

Benefits:

- Wide torque range
- High torque output
- High speed

Positive Clutch



A positive clutch ratchets upon reaching torque. Operator can increase torque output with forward/downward pressure.

Uses

- General assembly
- High prevailing torque
- Woodworking
- Soft joints

Benefits:

- Can provide higher rundown torque than seated torque
- Wide torque range

Stall



With a stall clutch, the air motor stalls out upon reaching torque. Torque is proportionate to the air pressure setting.

Uses

- Woodworking
- Soft joints
- Sheet metal screws

Benefits:

- Small, light tool
- Simple maintenance
- Torque adjusted by air pressure

Auto Shut-off

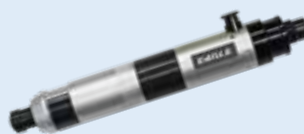

The auto-shutoff clutch has an internal cam that shuts off instantly upon reaching a preset torque level. It provides precise torque control.

Uses

- General assembly
- Critical applications
- All joint types
- High production

Benefits:

- Torque control
- Low maintenance
- Fast cycle times
- Low Noise

Impact



An impact clutch has a twin hammer impact mechanism.

Uses

- Industrial maintenance
- Tire service
- Heavy assembly

Benefits:

- Fast cycle times

STALL & ADJUSTABLE CLUTCH SCREWDRIVERS

1101 1/4" Stall Screwdriver

GENERAL DUTY



TORQUE RANGE: 10 - 45 in-lb

- 1/4" quick change chuck
- High power-to-weight ratio

1105 1/4" Stall Screwdriver

INDUSTRIAL DUTY



TORQUE RANGE: 20 - 52 in-lb

- 1/4" quick change chuck
- High power-to-weight ratio
- Side trigger for easy one-hand reverse

7P-1028-1 1/4" Stall Screwdriver

7P-0620-1 1/4" Stall Screwdriver

INDUSTRIAL DUTY



TORQUE RANGE: 13 - 32 in-lb



TORQUE RANGE: 18 - 45 in-lb

- Reversible bar on top enables one-hand operation
- Industrial-grade quick change chuck
- 3 Planet industrial-strength gear train provides durability for heavy-duty applications
- Improved muffler design
- Comfort-grip handle
- Spindle with special heat treatment

1102 1/4" Adjustable Clutch Screwdriver

GENERAL DUTY



TORQUE RANGE: 55 - 160 in-lb

- Cushion clutch
- Handle exhaust directs air away
- Convenient forward/reverse valve

Model	Application	Housing	Drive Size/ Chuck Capacity	Approx. Speed (rpm)	Approx. Torque Range		Weight		Length		Air Usage (cfm)	Air Inlet	Noise Level db(A)
					in-lb	Nm	lb	kg	in	mm			
1101	General	Sandcast aluminum	1/4" hex	1,800	10 - 45	1.1 - 5.1	3	1.4	7	178	16	1/4"	85
1105	Industrial	Sandcast aluminum	1/4" hex	800	20 - 52	2.3 - 5.9	1.5	0.7	5.1	130	14	1/4"	83
7P-1028-1	Industrial	Aluminum	1/4" QC	2,800	13 - 32	2.3 - 5.7	2.4	1.2	9.2	234	4	1/4"	88
7P-0620-1	Industrial	Aluminum	1/4" QC	2,000	18 - 45	3.2 - 8	2.3	1	8.5	216	4	1/4"	88
1102	General	Aluminum	1/4" hex	1,800	55 - 160	6.2 - 20.8	2.6	1.2	8.8	222	16	1/4"	83

POSITIVE CLUTCH SCREWDRIVERS

1115

1121

GENERAL DUTY



TORQUE RANGE: 190 - 475 in-lb

INDUSTRIAL DUTY



TORQUE RANGE: 166 - 415 in-lb

- 1/4" quick change chuck
- High power-to-weight ratio
- For wood and general assembly

	1115	1121
Application	General	Industrial
Housing	Aluminum	Sandcast aluminum
Drive Size/ Chuck Capacity	1/4" QC	1/4" QC
Approx. Speed (rpm)	1,800	1,800
Approx. Torque Range	190 - 475 in-lb 21.5 - 53.7 Nm	166 - 415 in-lb 18.8 - 46.9 Nm
Weight	2.6 lb / 1.2 kg	2.5 lb / 1.1 kg
Length	8" / 203 mm	6.8" / 171 mm
Air Usage (cfm)	16	16
Air Inlet	1/4"	1/4"
Noise Level db(A)	88	88

INDUSTRIAL DUTY



TORQUE RANGE: 120 - 372 in-lb

1550

1/4" Twin Hammer Impact Screwdriver

- No torque reaction
- Fast efficient tightening tool
- High power-to-weight ratio

1577

1/4" Impact Screwdriver

- 7 vane high speed motor
- Totally enclosed pinless impact mechanism with advanced heat treatment
- Tease throttle with 4-stop regulator for speed control and torque output
- 360° adjustable rear exhaust
- Detachable belt clip

INDUSTRIAL DUTY



TORQUE RANGE: 492 - 924 in-lb

Model	Application	Housing	Drive Size/ Chuck Capacity	Approx. Speed (rpm)	Approx. Torque Range		Weight		Length		Air Usage (cfm)	Air Inlet	Noise Level db(A)
					in-lb	Nm	lb	kg	in	mm			
1550	Industrial	Aluminum/steel	1/4" hex	10,500	120 - 372	13.6 - 42.2	1.2	0.55	6.8	173	2.5	1/4"	98
1577	Industrial	Aluminum	1/4" hex	10,000	492 - 924	55.6 - 104.4	2.3	1.04	6.5	165	29	1/4"	94

TORQUE CONTROLLED SCREWDRIVERS

TORQUE CONTROLLED PNEUMATIC SCREWDRIVERS

INDUSTRIAL DUTY

- Long lasting clutch design - 2,000,000 cycle tested
- Quick shut off clutch
- Accurate torque delivery
- Simple torque adjustment
- Great power to weight for best ergonomics

INLINE

EPTS-3300 Series

LIGHTWEIGHT
3.5 - 18.5 IN-LB
FREE SPEEDS: 1,100 / 1,700 / 2,300 RPM



EPTS-3400 Series

6.2 - 35.2 IN-LB
FREE SPEEDS: 800 / 1,500 / 2,100 RPM



PISTOL

EPTS-3300P Series

LIGHTWEIGHT
8.9 - 19.9 IN-LB
FREE SPEEDS: 1,100 / 1,700 / 2,300 RPM



EPTS-3400P Series

8.9 - 33.2 IN-LB
FREE SPEEDS: 800 / 1,500 / 2,100 RPM



EPTS-3500P Series

9.7 - 92.4 IN-LB
FREE SPEEDS: 500 / 800 / 1,700 RPM



ANGLE

EPTS-N3400 Series

9 - 110 IN-LB
FREE SPEED: 300 RPM



Model	Application	Housing	Drive Size/ Chuck Capacity	Approx. Speed (rpm)	Approx. Torque Range		Weight		Length		Air Usage (cfm)	Air Inlet	Noise Level db(A)
					in-lb	Nm	lb	kg	in	mm			
Inline													
EPTS-33011-25Q	Industrial	Aluminum	1/4" QC	1,100	9.7 - 18.5	1.1 - 2.1	0.9	0.4	7.4	187	7	1/4"	70
EPTS-33017-25Q	Industrial	Aluminum	1/4" QC	1,700	6.2 - 13.2	0.7 - 1.5	0.9	0.4	7.4	187	7	1/4"	70
EPTS-33023-25Q	Industrial	Aluminum	1/4" QC	2,300	3.5 - 13.2	0.4 - 1.5	0.9	0.4	7.4	187	7	1/4"	71
EPTS-34008-25Q	Industrial	Aluminum	1/4" QC	800	14.1 - 35.2	1.6 - 4	1.4	0.7	8.2	209	10.5	1/4"	70
EPTS-34015-25Q	Industrial	Aluminum	1/4" QC	1,500	9.7 - 23	1.1 - 2.6	1.4	0.7	8.2	209	10.5	1/4"	70
EPTS-34021-25Q	Industrial	Aluminum	1/4" QC	2,100	6.2 - 19.4	0.7 - 2.2	1.4	0.7	8.2	209	10.5	1/4"	74
Pistol													
EPTS-33011P-25Q	Industrial	Aluminum	1/4" QC	1,100	8.9 - 19.9	1 - 2.3	0.9	0.4	7.4	187	7	1/4"	70
EPTS-33017P-25Q	Industrial	Aluminum	1/4" QC	1,700	9.7 - 15.5	1.1 - 1.8	0.9	0.4	7.4	187	7	1/4"	70
EPTS-33023P-25Q	Industrial	Aluminum	1/4" QC	2,300	10.2 - 17.7	1.2 - 2	0.9	0.4	7.4	187	7	1/4"	71
EPTS-34008P-25Q	Industrial	Aluminum	1/4" QC	800	14.2 - 33.2	1.6 - 3.8	1.4	0.7	8.2	209	10.5	1/4"	70
EPTS-34015P-25Q	Industrial	Aluminum	1/4" QC	1,500	8.9 - 26.6	1 - 3	1.4	0.7	8.2	209	10.5	1/4"	70
EPTS-34021P-25Q	Industrial	Aluminum	1/4" QC	2,100	10.6 - 24.3	1.2 - 2.8	1.4	0.7	8.2	209	10.5	1/4"	74
EPTS-35005P-25Q	Industrial	Aluminum	1/4" QC	500	44 - 92.4	5 - 10.5	2.2	1	9.5	241	17.5	1/4"	74
EPTS-35008P-25Q	Industrial	Aluminum	1/4" QC	800	26.4 - 48.4	3 - 5.5	2.2	1	9.5	241	17.5	1/4"	75
EPTS-35017P-25Q	Industrial	Aluminum	1/4" QC	1,700	9.7 - 23	1.5 - 2.6	2.2	1	9.5	241	17.5	1/4"	75
Angle													
EPTS-N34003-25	Industrial	Aluminum	1/4" sq	300	9 - 110	1 - 12	2.4	1.08	14.5	368	17.5	1/4"	75
EPTS-N34003-38	Industrial	Aluminum	3/8" sq	300	9 - 110	1 - 12	2.4	1.08	14.5	368	17.5	1/4"	75

>> ASSEMBLY TOOLS

SIW SHUT-OFF IMPACT WRENCH

INDUSTRIAL DUTY



SERIES TORQUE RANGE: 2 - 89 ft-lb

- Operates as a standard impact wrench or as an impact wrench with a programmable shut-off point
- Brushless motor provides longer motor life and increased efficiency
- Easy-to-read process information lights
- LED light for work-area illumination
- Programmable buttons
- Mini USB port for connection to optional programmer (SPC-2PGM)
- Li-Ion battery provides long battery life

SIW SERIES ACCESSORIES

SIW-B20LI Li-Ion Battery

- 20V, 2.0 Ah



SIW-B20LI-HC High Capacity Li-Ion Battery

- 20V, 4.0 Ah



SIW-C18-20 Battery Charger

- Output: 18 - 20V, 4.0 Ah
- Input: 100 - 240VAC, 50 - 60 Hz



BJ10091 Body Jacket Cover



SIW-PBL Suspension Bail



SIW-38PR (3/8" Dr.) SIW-50PR (1/2" Dr.) Pin Retainer Kits



Model	Application	Housing	Drive Size	Approx. Speed (rpm)	Approx. Torque Range		Max Torque		Battery V	Weight		Noise Level db(A)
					ft-lb	Nm	ft-lb	Nm		lb	kg	
SIW-P2525Q	Industrial	Composite	1/4" QC	2,400	2 - 18	3 - 25	30	40	20	2.2	1	71
SIW-P3225Q	Industrial	Composite	1/4" QC	2,400	4 - 24	6 - 32	66	90	20	2.2	1	71
SIW-P3238	Industrial	Composite	3/8" Sq Dr	2,400	4 - 24	6 - 32	66	90	20	2.2	1	71
SIW-P5538	Industrial	Composite	3/8" Sq Dr	2,400	11 - 41	15 - 55	90	120	20	2.4	1.1	71
SIW-P5550	Industrial	Composite	1/2" Sq Dr	2,400	11 - 41	15 - 55	90	120	20	2.4	1.1	71
SIW-P10050	Industrial	Composite	1/2" Sq Dr	2,400	18 - 74	25 - 100	133	180	20	2.4	1.1	71
SIW-P12050	Industrial	Composite	1/2" Sq Dr	2,400	22 - 89	30 - 120	210	210	20	2.9	1.3	71

Shut-Off Impact Tools Include: Body Jacket, Bail, and one (1) 18V Li-Ion Battery

ASSEMBLY TOOLS

Signature Series CORDLESS TOOLS



SPC PRECISION CLUTCH TOOLS

INDUSTRIAL DUTY

SERIES TORQUE RANGE: 0.6 - 74 ft-lb

- LED indicator provides simple process information to the operator. The signal is visible from any angle
- Press button for easy F/R operation
- LED light for working in dark areas
- Trigger repeat protection avoids double hits on already seated screws
- Easily attached sliding battery system
- Mini USB port for connection to optional programmer (SPC-2PGM)
- Li-Ion battery pack delivers longer run time
- Ergonomic handle design provides outstanding balance and weight and is ideal for accessing hard-to-reach locations
- Angle tool enables multiple head positions

Model	Application	Housing	Drive Size	Free Speed Range (rpm)	Approx. Torque Range		Battery V	Weight		Noise Level db(A)
					ft-lb	Nm		lb	kg	
Pistol Nutrunner*										
SPC-P2325Q	Industrial	Composite	1/4" hex	500 - 1,550	0.6 - 2.2	0.8 - 3	18	2.1	0.95	75
SPC-P2625Q	Industrial	Composite	1/4" hex	300 - 1,000	0.7 - 4.4	1.0 - 6	18	2.1	0.95	75
SPC-P2925Q	Industrial	Composite	1/4" hex	300 - 800	1.1 - 6.6	1.5 - 9	18	2.1	0.95	75
SPC-P21225Q	Industrial	Composite	1/4" hex	250 - 600	1.5 - 8.8	2 - 12	18	2.1	0.95	75
Right Angle Nutrunner**										
SPC-A21025Q	Industrial	Composite	1/4" hex	400 - 1,000	2.2 - 8.8	3 - 12	18	3.5	1.6	75
SPC-A21025	Industrial	Composite	1/4" Sq	400 - 1,000	2.2 - 8.8	3 - 12	18	3.5	1.6	75
SPC-A21038	Industrial	Composite	3/8" Sq	400 - 1,000	2.2 - 8.8	3 - 12	18	3.5	1.6	75
SPC-A21625Q	Industrial	Composite	1/4" hex	300 - 600	3.7 - 13.3	5 - 18	18	3.5	1.6	75
SPC-A21625	Industrial	Composite	1/4" Sq	300 - 600	3.7 - 13.3	5 - 18	18	3.5	1.6	75
SPC-A21638	Industrial	Composite	3/8" Sq	300 - 600	3.7 - 13.3	5 - 18	18	3.5	1.6	75
SPC-A23038	Industrial	Composite	3/8" Sq	250 - 480	5.9 - 22	8 - 30	18	3.5	1.6	75
SPC-A23538	Industrial	Composite	3/8" Sq	220 - 330	7.4 - 25.8	10 - 35	18	3.5	1.6	75
SPC-A25038	Industrial	Composite	3/8" Sq	200 Non-Programmable Fixed Speed***	7.4 - 37	10 - 50	18	5.3	2.4	75
SPC-A27038	Industrial	Composite	3/8" Sq	170 Non-Programmable Fixed Speed***	14.8 - 51.7	20 - 70	18	6.3	2.9	75
SPC-A210050	Industrial	Composite	1/2" Sq	119 Non-Programmable Fixed Speed***	26 - 74	35 - 100	18	7.4	3.4	75

* Pistol Grip Tools include: Torque Adjustment Tool and one (1) 18V Li-Ion Battery

** Angle Nutrunners include: Torque Adjustment Tool, Head Indexing Spanner Wrench, and one (1) 18V Li-Ion Battery

*** High torque tools feature fixed RPM

Signature Series CORDLESS TOOLS

SPC SERIES ACCESSORIES

SPC-B218LI Li-Ion Battery

- 18V, 2.0 Ah



SPC-B218LI-HC High Capacity Li-Ion Battery

- 18V, 4.0 Ah



BJ10082 Pistol Tool Body Jacket Cover



BJ10083 Angle Tool Body Jacket Cover



SPC-C218-19 Battery Charger

- Output:
18 - 19.2V, 3.0 Ah
- Input:
100 - 240VAC, 50 - 60 Hz



SPC-P-HL-RH (Right Hand) SPC-P-HL-LH (Left Hand) Tool Holster

- Designed for
Signature Series
pistol and angle
tools



21226 Tool Basket

- Designed for
Signature
Series
pistol and
angle tools
- Can be affixed to a
bench or rack



SPC-QC Quick Clip

- Designed for
Signature Series
pistol tools
- Comes with a belt
clip and a stretch
cord attachment
- Ball feature
allows for quick
and easy release



Tool Speed Programmer



SPC-2PGM

Each Signature Series battery tool has programmable features that enhance operator efficiency. Programmable features include:

- Tool speed control from minimum (1,500 rpm) to maximum (2,400 rpm) speed in 50 rpm increments
- Forward/Reverse Mode - Three setting options
- Two-stage trigger delay control
- Screw count / impact count
- Supervisor level "lock-out" control

Additionally, the Signature Series battery tool has an integrated mini USB connector that couples to the Signature Series Programmer module. Simply connect the tool to the Programmer Module and flash the tool to the desired RPM. The programmed RPM will remain until a change is desired.

DRILLS DRILLS

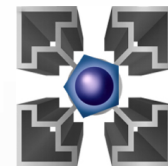

*Rugged construction,
powerful air motors,
and varied RPMs*

provide you many options for selecting the ideal Eagle Group drill for your job. These drills are designed for precision drilling, honing, hole sawing, wood boring, counter-sinking, and wire brushing applications.

7005 1/4" Reversible Drill

GENERAL DUTY



1,800 RPM

- Easy reach reverse selector
- Equipped with Jacobs Chuck®
- Bottom handle exhaust

7110 3/8" Reversible Drill

GENERAL DUTY



1,800 RPM

7650 3/8" Reversible Angle Drill

GENERAL DUTY



1,500 RPM

- For general purpose drilling in confined areas
- Convenient forward/reverse button
- Rear exhaust
- Equipped with Jacobs Chuck®

7100 3/8" Inline Drill, Non-Reversible

GENERAL DUTY



1,500 RPM

- Inline design for tight space applications
- Ribbed steel housing for better grip

7102 3/8" Reversible Drill

GENERAL DUTY



1,800 RPM

- Positive action trigger controls speed
- For drilling, counter sinking, and wire brushing

Model	Application	Housing	Chuck Capacity	Reversible/ Non-Reversible	Approx. Power (hp)	Approx. Speed rpm	Weight		Length		Air Usage (cfm)	Air Inlet
							lb	kg	in	mm		
7005	General	Composite/steel	1/4" Jacobs	Reversible	0.6	1,800	1.8	0.8	7.2	184	13.7	1/4"
7110	General	Composite/steel	3/8" Jacobs	Reversible	0.6	1,800	1.8	0.8	7.2	184	13.7	1/4"
7650	General	Aluminum/steel	3/8" Jacobs	Reversible	0.6	1,500	2.3	1	8.3	211	14	1/4"
7100	General	Aluminum/steel	3/8"	Non-Reversible	0.4	1,500	2.3	1	9	229	16	1/4"
7102	General	Sandcast aluminum/steel	3/8"	Reversible	0.5	1,800	3	1.4	7	178	16	1/4"

>>> DRILLS

7107
3/8" Reversible Drill

GENERAL DUTY



2,600 RPM

- Positive action trigger controls speed
- For drilling, counter sinking, and wire brushing

7107	
Application	General
Housing	Aluminum/steel
Chuck Capacity	3/8"
Reversible / Non-reversible	Non-reversible
Approx. Speed (rpm)	2,600
Approx. Power (hp)	0.6
Weight	4 lb / 1.8 kg
Length	7" / 178 mm
Air Usage (cfm)	20
Air Inlet	1/4"

VARIABLE-SPEED INDUSTRIAL DRILLS

REVERSIBLE

714P-2100R
1/4" Drill



2,100 RPM

NON-REVERSIBLE

738P-3200
3/8" Drill



3,200 RPM

712P-420
1/2" Drill



420 RPM

712P-5100
1/2" Drill



5,100 RPM

- Precision machined gears
- Robust sandcast aluminum housing
- Steel front end
- Ergonomic handle design
- Equipped w/Jacobs Chuck®
- Variable speed trigger
- Muffled directional rear exhaust

Model	Application	Housing	Chuck Capacity	Reversible/ Non-Reversible	Approx. Power (hp)	Approx. Speed (rpm)	Weight		Length		Air Usage (cfm)	Air Inlet
							lb	kg	in	mm		
714P-2100R	Industrial	Sandcast aluminum/steel	1/4" Jacobs	Reversible	0.6	2,100	1.6	0.73	6.87	175	16	1/4"
738P-3200	Industrial	Sandcast aluminum/steel	3/8" Jacobs	Non-reversible	0.6	3,200	2.65	1.2	7.25	184	16	1/4"
712P-420	Industrial	Sandcast aluminum/steel	1/2" Jacobs	Non-reversible	1	420	2.95	1.34	8.5	216	16	1/4"
712P-5100	Industrial	Sandcast aluminum/steel	1/2" Jacobs	Non-reversible	0.6	5,100	2.35	1.07	7.12	181	16	1/4"

ONE-HAND OPERATION, INDUSTRIAL REVERSIBLE DRILLS

- Reversible bar on top enables one-hand operation
- Industrial-grade chuck
- 3 Planet industrial-strength gear train provides durability for heavy-duty drilling
- Improved muffler design
- Comfort-grip handle
- Spindle with special heat treatment

0.6 HP MODELS



Keyed
7P-0620-2: 1/4"
7P-0620-4: 3/8"
7P-0620-6: 1/2"

Application	Industrial
Housing	Sandcast aluminum/steel
Reversible/Non-Reversible	Reversible
Approx. Power (hp)	0.6
Approx. RPM	2,000
Weight	2.3 lb / 1 kg
Length	8.5" / 216 mm
Air Usage (cfm)	4
Air Inlet	1/4"



Keyless
7P-0620-5: 3/8"
7P-0620-7: 1/2"

1.0 HP MODELS



Keyed
7P-1028-4: 3/8"
7P-1028-6: 1/2"

Application	Industrial
Housing	Sandcast aluminum/steel
Reversible/Non-Reversible	Reversible
Approx. Power (hp)	1
Approx. RPM	2,800
Weight	2.4 lb / 1.2 kg
Length	9.2" / 234 mm
Air Usage (cfm)	4
Air Inlet	1/4"



Keyless
7P-1028-5: 3/8"
7P-1028-7: 1/2"

>> DRILLS

GENERAL DUTY



500 RPM

7105

1/2" Drill, Non-Reversible

- Positive action trigger controls speed
- For drilling, counter sinking, and wire brushing

GENERAL DUTY



800 RPM

7106

1/2" Reversible Drill

- Positive action trigger controls speed
- For drilling, counter sinking, and wire brushing

Model	Application	Housing	Chuck Capacity	Reversible/ Non-Reversible	Approx. Power (hp)	Approx. Speed (rpm)	Weight		Length		Air Usage (cfm)	Air Inlet
							lb	kg	in	mm		
7105	General	Aluminum/steel	1/2"	Non-Reversible	0.6	500	4	1.8	7	178	20	1/4"
7106	General	Aluminum/steel	1/2"	Reversible	0.6	800	4	1.8	7	178	20	1/4"



PERCUSSION TOOLS PERCUSSION TOOLS

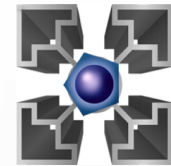

*Tough jobs
require tough tools*
and Eagle Group's durable
hammers, chippers, and needle
scalers offer the long-lasting
power you need for both general and
industrial applications. Ideal for foundries,
fabrication shops, shipbuilding, and
construction applications.



4100
Air Hammer
2.375" Stroke

- Positive action trigger controls speed
- Heavy-duty spring retainer

4001
Air Hammer
2.625" Stroke



- Economical air hammer for fast cutting action
- For muffler and pipe removal, body shop work, scraping rust, and light front-end work
- For exhaust system, panel cutting, and general repair work
- Includes 6" chisel with 1-3/8" angle blade



4178
Air Hammer
3.625" Stroke

- Heavy-duty spring retainer
- Long lasting
- For front end, exhaust, frame, and body work

4260
Air Hammer
3.75" Stroke



- Feathering throttle for control
- Heavy-duty spring retainer
- For riveting applications

4009
Chipping Hammer
2" Stroke

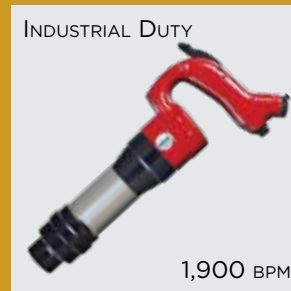

4010
Chipping Hammer
3" Stroke

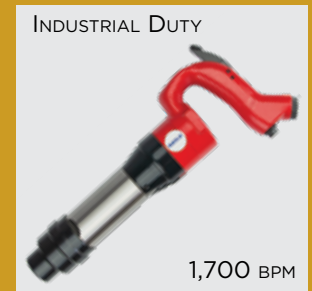

- Drop forged handle
- Front exhaust
- Oval collar
- For paint, scale, and rust removal

Model	Application	Housing	For use with	Chisel Shank	Bore (in)	Stroke (in)	Approx. bpm	Weight lb	kg	Length in	mm	Air Usage (cfm)	Air Inlet
4100	General	Aluminum/steel	Chisel	0.401"	0.75	2.375	2,100	3.3	1.5	7.8	198	10	1/4"
4001	General	Aluminum/steel	Chisel	0.401"	0.75	2.625	3,500	3.8	1.7	6.8	171	15	1/4"
4178	Industrial	Aluminum/steel	Chisel	0.401"	0.75	3.625	2,100	4.3	2	8.5	216	12	1/4"
4260	General	Aluminum/steel	Chisel	0.498"	0.75	3.750	1,800	5.5	2.5	7.8	198	12	1/4"
4009	Industrial	Aluminum/steel	Chisel	.68 round or .58 hex bushing	1.125	2.0	1,900	16	7.3	15.5	394	12	1/2"
4010	Industrial	Aluminum/steel	Chisel	.68 round or .58 hex bushing	1.125	3.0	1,700	17.8	8.1	16.3	413	12	1/2"

PERCUSSION TOOLS

NEEDLE SCALERS & FLUX CHIPPERS

4004
Flux Chipper
1.5" Stroke

4005
Needle Scaler
1.5" Stroke

4005SC
Needle Scaler/
Chipper, 1.5" Stroke

INDUSTRIAL DUTY



4,600 BPM

4,600 BPM

4,600 BPM

- Hardened barrels and strict tolerances for maximum life
- Scaler: For foundries, fabrication shops, ship building, and construction
- Chipper: For rust weld slag, and old paint removal

	4004	4005	4005SC
Application	Industrial		
Housing	Steel		
For Use With	7" Angle Chisel (730224C)	Needles (9024/9043)	Needles (9024/9043) 7" Angle Chisel (730224C)
Needle/Chisel Diameter	Chisel: 0.373"	19 @ 3 mm each	19 @ 3 mm each Chisel: 0.373"
Bore	1"		
Stroke	1.5"		
Approx. BPM	4,600		
Weight	5.8 lb / 2.6 kg	6.2 lb / 2.8 kg	6.2 lb / 2.8 kg
Length	9.8" / 248 mm	18" / 457 mm	18" / 457 mm
Air Usage (cfm)	12		
Air Inlet	1/4"		

ACCESSORIES

9024 / 9043
Replacement
Needles

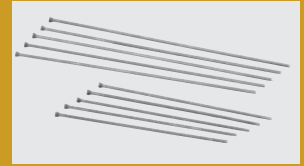

For 4005, 4005SC, 4615, and 4620 needle scalars. Sold as individual needles (see tool set requirements).

	Length	Diameter
9024	7" 175 mm	5" 125 mm
9043	1/8" 3.18 mm	1/8" 3.18 mm

730224C
7" Angle Chisel



For 4004 and 4005SC flux chippers

4615
Mini Needle Scaler
2.375" Stroke

INDUSTRIAL DUTY



4,000 BPM

- Straight handle for hard-to-reach areas
- 12-piece 3 mm needle set included
- For rust, weld slag, and old paint removal

4620
Pistol Needle Scaler
2.375" Stroke

INDUSTRIAL DUTY



4,500 BPM

- Heavy-duty scaler with pistol grip
- 28-piece 3 mm needle set included
- For rust, weld slag, and old paint removal

Model	Application	Housing	For use with	Needle/Chisel Diameter	Bore (in)	Stroke (in)	Approx. bpm	Weight		Length		Air Usage (cfm)	Air Inlet
								lb	kg	in	mm		
4615	Industrial	Steel	Needles (9024/9043)	12 @ 3 mm each	1	2.375	4,000	2.8	1.3	11.5	292	4	1/4"
4620	Industrial	Aluminum/steel	Needles (9024/9043)	28 @ 3 mm each	1	2.375	4,500	8	3.6	13.8	351	7	1/4"

CUTTING & SPECIALTY TOOLS

CUTTING & SPECIALTY TOOLS

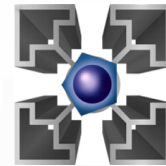

Eagle Group offers a variety of speciality tools, including saws, cut-off tools, tire buffers, and blow guns.

6050 Reciprocating Saw

- High performance motor provides aggressive cutting action
- Insulated handle
- For cutting plastics, fiberglass, and sheet metal

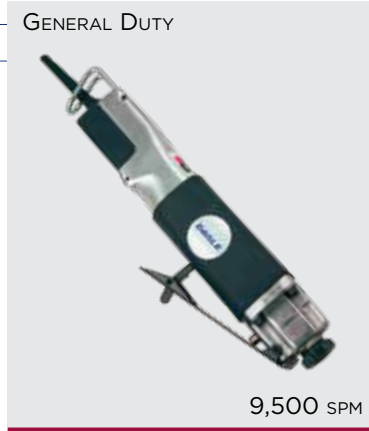

6080 Low-Vibration Reciprocating Saw

- 35% longer stroke for "quicker and thicker" material cuts
- Patented vibration-damped cylinder design decreases vibration emission by 40%
- Patented blade guard prevents metal filing from entering the inner mechanism



Model	Application	Housing	Approx. spm	Teeth	Stroke (mm)	Weight		Length		Air Usage (cfm)	Air Inlet
						lb	kg	in	mm		
6050	General	Aluminum	9,500	14 / 24 / 32	10	2.2	1	9.3	236	7	1/4"
6080	Industrial	Aluminum	10,000	24 / 32	14	1.37	0.62	8.9	227	2.3	1/4"

INDUSTRIAL BACK-GOUGING ANGLE SAWS

5A-0514-2 Back-Gouging Mini Saw

- Industrial-grade and compliant tool design ensures fast and effective back-gouging
- Angle height: 1.75"
- 2" carbide tooth blade (#0514-2) sold separately
- For gouging tight access seams



BLADE SOLD SEPARATELY

5G-10125 5" Angle Saw

- Left/right hand use
- Governed motor
- Removable base plate
- Side to Side: 31 mm from front blade edge to shoe edge
- Depth Cut Adjustment:
Min: 1/8" (3 mm)
Max: 1" (12.5 mm)



BLADE SOLD SEPARATELY

Model	Application	Housing	Max Blade Diameter	Arbor	Power (hp)	Approx. Speed (rpm)	Max. Blade Exposure	Throttle Type	Exhaust	Weight		Length		Air Usage (cfm)	Air Inlet
										lb	kg	in	mm		
5A-0514-2	Industrial	Steel	2"	3/8"-24	0.5	14,000	—	Lever	Side	3	1.4	8.5	216	15	1/4"
5G-10125	Industrial	Aluminum	5"	5/8"-11	1.0	12,000	0.75"	Lever	Rear	3.95	1.8	11	279	30	3/8"

>> CUTTING & SPECIALTY

CUT-OFF TOOLS, PUNCH/FLANGE KIT, & BLOW GUN

5205-2EC

3" Cut-Off Tool, 105°

- Ergonomic and safe use design
- 105° angled head design provides improved sight lines and spark angle
- Tight access use
- 1/16" to 1/4" wheel capability

GENERAL DUTY



15,000 RPM

6812EC

3" Cut-Off Tool

- Lightweight and durable ergonomic composite housing with a soft comfortable grip
- Less noise, vibration, and thermal transfer than aluminum tools
- Protective metal guard

INDUSTRIAL DUTY



20,000 RPM

6191

3" Cut-Off Tool

- Rear exhaust directs exhaust air away
- Lock-off throttle prevents accidental start-up
- For cutting muffler clamps, and use in body shops

INDUSTRIAL DUTY



24,000 RPM

8116

Suction/Blow Gun

INDUSTRIAL DUTY



- Reversible nozzle ring creates portable vacuum cleaner
- Acts as a blow gun on reverse side
- Includes two nozzles
- Bag included

8116

Application	Industrial
Housing	Composite
Capacity	6.3 cfm
Tip Accessories	2
Weight	1 lb / 0.4 kg
Length	5.7" / 144 mm
Air Inlet	1/4"

Model	Application	Housing	Max. Disc Size	Approx. Speed (rpm)	Weight		Length		Air Usage (cfm)	Air Inlet
					lb	kg	in	mm		
5205-2EC	General	Composite	3"	15,000	1.5	0.68	8.25	210	12	1/4"
6812EC	Industrial	Composite	3"	20,000	1.7	0.77	7.38	187	3	1/4"
6191	Industrial	Aluminum	3"	24,000	2	0.9	8	203	10	1/4"

GENERAL DUTY



2,500 RPM

5114

Low-Speed Tire Buffer

- Built-in air regulator
- Quick change chuck
- Rib textured handle for firm grip
- Piped away exhaust kit available
- Includes 7/16" quick change adapter with 3/8"-24 male end

5077

Low-Speed Tire Buffer

- Specifically designed for recapping, tire scuffing and roughing
- Complete with air hose, exhaust hose, and integral silencer
- With 3/8" Jacobs® Chuck & key

GENERAL DUTY



3,400 RPM

5072

High-Speed Tire Buffer

- Specifically designed for recapping, tire scuffing, and roughing
- Complete with air hose, exhaust hose, and integral silencer
- With 3/8" Jacobs® Chuck & key

GENERAL DUTY



19,000 RPM

Model	Application	Housing	Collet Size	Approx. Power (hp)	Approx. Speed (rpm)	Throttle Type	Exhaust	Weight		Length		Air Usage (cfm)	Air Inlet
								lb	kg	in	mm		
5114	General	Aluminum/steel	7/16" QC	0.5	2,500	Lever	Rear	2.5	1.1	8.5	216	17	1/4"
5077	General	Aluminum/steel	3/8" Jacobs	0.54	3,400	Lever	Rear	2	0.9	7.8	198	18	1/4"
5072	General	Aluminum/steel	3/8" Jacobs	0.54	19,000	Lever	Rear	2	0.9	7.8	198	18	1/4"

CUTTING & SPECIALTY

TOOLS FOR THE TIRE INDUSTRY

UG-60S-29

1/4" 0.50 HP Low-Speed Tire Buffer

- Low speed allows for powerful smooth buffing with no burning or scorching of work surface
- Contoured, ergonomic handle
- Rear muffled exhaust
- Includes spanner wrench to tighten collet



UG-65EBL-ASSY

0.60 HP Horizontal Lightweight Tire Buffer

- Rear muffled exhaust
- Designed for medium-sized tire repair
- Excellent with carbide contour or vane wheels up to 2-1/2"
- Four-bearing construction guarantees long life under heavy usage



USG-4VL

0.60 HP Horizontal Tire Buffer

- Lightweight grinder allows one-hand operation
- Quiet rear exhaust and muffler
- For surface preparation work
- Eliminates heavy shaft drag, dramatically reducing operator fatigue



UG-1250LM

1.0 HP Horizontal Tire Buffer

- Piped away rear exhaust muffles sound and eliminates blowing dust
- Governed motor for fast rubber removal using a cup cutter
- Excellent for inside or outside OTR work and truck rim cleanup with wire brush
- Comes with box muffler and piped away exhaust hose

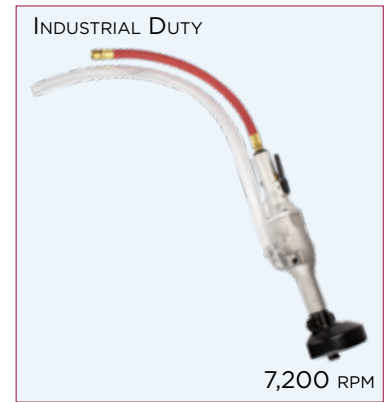

Model	Application	Housing	Collet Size	Capacity (wheel size) in	Approx. Power (hp)	Approx. Speed (rpm)	Throttle Type	Exhaust	Weight		Length		Air Usage (cfm)	Air Inlet
									lb	kg	in	mm		
UG-60S-29	Industrial	Sandcast Aluminum	1/4"	—	0.5	2,900	Lever	Rear	2.3	1.1	8.9	227	18	1/4"
UG-65EBL-ASSY	Industrial	Sandcast Aluminum	—	2.5	0.6	14,600	Lever	Rear	3.1	1.4	10.7	272	22	1/4"
USG-4VL	Industrial	Sandcast Aluminum	—	4	0.6	12,000	Lever	Rear	3.1	1.4	8.7	220	30	1/4"
UG-1250LM	Industrial	Sandcast Aluminum	—	5	1	7,200	Lever	Piped-Away Side	6.2	2.8	17.2	436	32.7	3/8"

ACCESSORIES

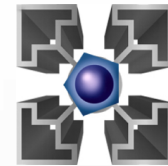

*Optimize your
tool's performance*
with Eagle Group's full line
of accessories.

Eagle Group: Your full-service industrial tool source

Auditor's APTW preset wrenches provide a flexible, easy way to audit fastener torque. A wide range of interchangeable heads provide flexibility and convenience.



- Torque ranges from 5 - 340 Nm
- User friendly, sleek, ergonomic design
- Tactile feedback on achievement of preset torque
- Proprietary adjustment tool guards against unauthorized setting changes
- Wide range of interchangeable heads provide flexibility and convenience
- +/- 3% accuracy when used in clockwise or counterclockwise directions









Wrench Model	Torque Range	Insert Accepted
APTW-25	5 - 25 Nm	12 mm
APTW-50	10 - 50 Nm	12 mm
APTW-100	20 - 100 Nm	12 mm
APTW-150	30 - 150 Nm	12 mm
APTW-200	40 - 200 Nm	14 mm
APTW-340	60 - 340 Nm	14 mm







TORQUE WRENCH INSERTS





Adapters	Description
 APTW-12ADP	9 x 12 M to 14 x 18 F
 APTW-14ADP	14 x 18 M to 9 x 12 F

Ring End Inserts	Description
 APTW-12RE50	1/2" Ring End, 12 mm
 APTW-14RE32	32 mm Ring End, 14 mm

Square Drive Inserts	Description
9 x 12	
 APTW-12SD25	1/4" Sq. Dr.
 APTW-12SD38	3/8" Sq. Dr.
 APTW-12SD50	1/2" Sq. Dr.
14 x 18	
 APTW-14SD50	1/2" Sq. Dr.

Blank End Inserts	Description
 APTW-12BLANK	12 mm
 APTW-14BLANK	14 mm

Open End Head Inserts	
	

Ratchet Heads	Description
9 x 12	
 APTW-12RT25	1/4" Sq. Dr.
 APTW-12RT38	3/8" Sq. Dr.
 APTW-12RT50	1/2" Sq. Dr.
14 x 18	
 APTW-14RT50	1/2" Sq. Dr.
 APTW-14RT34	3/4" Sq. Dr.

9 x 12	Size	14 x 18	Size	14 x 18	Size
APTW-12OE7	7 mm OE	APTW-14OE1	1" OE	APTW-14OE30	30 mm OE
APTW-12OE8	8 mm OE	APTW-14OE13	13 mm OE	APTW-14OE32	32 mm OE
APTW-12OE9	9 mm OE	APTW-14OE14	14 mm OE	APTW-14OE34	34 mm OE
APTW-12OE10	10 mm OE	APTW-14OE15	15 mm OE	APTW-14OE36	36 mm OE
APTW-12OE11	11 mm OE	APTW-14OE16	16 mm OE	APTW-14OE38	38 mm OE
APTW-12OE12	12 mm OE	APTW-14OE17	17 mm OE	APTW-14OE41	41 mm OE
APTW-12OE13	13 mm OE	APTW-14OE18	18 mm OE	APTW-14OE118	1-1/8" OE
APTW-12OE14	14 mm OE	APTW-14OE19	19 mm OE,	APTW-14OE138	1-3/8" OE
APTW-12OE15	15 mm OE	APTW-14OE21	21 mm OE		
APTW-12OE16	16 mm OE	APTW-14OE22	22 mm OE		
APTW-12OE17	17 mm OE	APTW-14OE24	24 mm OE		
APTW-12OE18	18 mm OE	APTW-14OE25	25 mm OE		
APTW-12OE19	19 mm OE	APTW-14OE27	27 mm OE		
APTW-12OE20	20 mm OE				
APTW-12OE50	1/2" OE				

>>> ACCESSORIES

AUDITOR TORQUE CUBE



ATC-10
ATC-25
ATC-100
ATC-250
ATC-500
ATC-750
ATC-1800



ATC-150F
ATC-250F
ATC-500F
ATC-750F



The Auditor Torque Cube (ATC) is a compact, versatile desktop tester that provides a multitude of capabilities. The ATC is designed to test hand or power tools with the following:

- Peak, first peak, and track modes
- Multiple engineering units
- Manual and auto clear function
- Multiple frequency response settings
- Bi-directional use and accuracy
- Accuracy is better than 1% of indicated reading top 90% of range
- Serial data output
- Memory: 999 data samples
- Battery and/or mains powered

Because precision and quality are critical, you can depend on our testers to calibrate and certify your tools. Whether you are assembling large complicated systems or small precise time pieces, AIMCO provides the best system for your application. Our instruments have been judged “best in class” by independent National Standards laboratories. Auditor Torque Cube is rugged enough to test and verify tools at “point of use” while still being accurate enough to calibrate hand and power tools.

Each tester is shipped with a mains/battery charger power cord, a hex to allen drive bit, and a bolting template. Models with max torque of 1,000 in-lb or less also include a joint rundown fixture. The ATC can be positioned vertically or horizontally for the ergonomic testing of inline or pistol grip tools.

Model	Recommended Torque Range		Weight		W x H x D		Sq. Dr.
	Nm	in-lb/ft-lb	kg	lb	mm	in	
Vertical Configuration							
ATC-10	0.13 - 1.13	1 - 10 in-lb	1.13	2.5	79 x 95 x 83	3.13 x 3.75 x 3.25	1/4"
ATC-25	0.28 - 2.83	2.5 - 25 in-lb	1.13	2.5	79 x 95 x 83	3.13 x 3.75 x 3.25	1/4"
ATC-100	1.13 - 11.3	10 - 100 in-lb	1.13	2.5	79 x 95 x 83	3.13 x 3.75 x 3.25	1/4"
ATC-250	2.83 - 28.3	25 - 250 in-lb	1.13	2.5	79 x 95 x 83	3.13 x 3.75 x 3.25	3/8"
ATC-500	5.65 - 56.5	50 - 500 in-lb	1.13	2.5	79 x 95 x 83	3.13 x 3.75 x 3.25	3/8"
ATC-750	8.47 - 84.8	75 - 750 in-lb	1.13	2.5	79 x 95 x 83	3.13 x 3.75 x 3.25	3/8"
ATC-1800	21.2 - 203	188 - 1,800 in-lb	1.13	2.5	79 x 95 x 83	3.13 x 3.75 x 3.25	1/2"
Horizontal Configuration							
ATC-150F	20 - 200	15 - 150 ft-lb	2.25	5	79 x 95 x 83	3.13 x 3.75 x 3.25	1/2"
ATC-250F	34 - 340	25 - 250 ft-lb	2.25	5	79 x 95 x 83	3.13 x 3.75 x 3.25	1/2"
ATC-500F	68 - 678	50 - 500 ft-lb	2.25	5	79 x 95 x 83	3.13 x 3.75 x 3.25	3/4"
ATC-750F	102 - 1,017	75 - 750 ft-lb	2.25	5	79 x 95 x 83	3.13 x 3.75 x 3.25	3/4"



AUET



AUET/MTM



AUET/MTM-DC

AUDITOR UNIVERSAL ELECTRONIC TORQUE TESTERS

Auditor Universal Electronic Testers (AUET) have a broad range of features to accommodate most requirements. They are designed to be bench-top mounted and are available in several configurations and various single or multiple torque ranges. Onboard memory allows you to capture 999 torque event readings. The testers are also available in file capability (DC) models that require PC software Auditor Tool Manager (ATM).

Instruments up to 1,000 in-lb are supplied with rundown adapters/joint kits. Rundown kits for larger instruments can be ordered separately. AUET/MTM units are supplied with an external transducer port and selector switch for connecting additional transducers.

AUET testers utilize the same transducers as the ATC instruments, providing the same high quality accuracy and durability. The common interface makes the Auditor tester extremely user friendly.

Single Transducer Models

Model*	Recommended Torque Range
AUET-050(-DC)	5 - 50 in-oz / 0.4 - 3.6 kgf-cm
AUET-0100(-DC)	10 - 100 in-oz / 0.7 - 7.2 kgf-cm
AUET-10(-DC)	1 - 10 in-lb / 1.1 - 11.5 kgf-cm
AUET-50(-DC)	5 - 50 in-lb / 0.5 - 5.6 Nm
AUET-100(-DC)	10 - 100 in-lb / 1.1 - 11.3 Nm
AUET-250(-DC)	25 - 250 in-lb / 2.8 - 28.3 Nm
AUET-500(-DC)	50 - 500 in-lb / 5.7 - 56.5 Nm
AUET-1000(-DC)	100 - 1,000 in-lb / 11.3 - 113 Nm
AUET-1200(-DC)	120 - 1,200 in-lb / 13.6 - 135.6 Nm
AUET-1800(-DC)	180 - 1,800 in-lb / 20.3 - 203.4 Nm

* Add "-DC" to part numbers for data collecting models.

Data collecting models allow multiple files/tools/applications to be associated with torque data. Requires Tool Manager software.

Custom sizes are also available. Contact an (800) 852-1368 Customer Service Associate for ordering options, (503) 254-6600, or toll free (800) 852-1368.

Dual Transducer Models

Model*	Recommended Torque Range	
	Transducer 1	Transducer 2
AUET/MTM-050-25	5 - 50 in-oz / 0.04 - 0.4 Nm	2.5 - 25 in-lb / 0.3 - 2.8 Nm
AUET/MTM-050-600(-DC)	5 - 50 in-oz / 0.04 - 0.4 Nm	60 - 600 in-lb / 6.8 - 67.8 Nm
AUET/MTM-0100-050(-DC)	10 - 100 in-oz / 0.07 - 0.71 Nm	5 - 50 in-oz / 0.04 - 0.4 Nm
AUET/MTM-10-100(-DC)	1 - 10 in-lb / 0.11 - 1.12 Nm	10 - 100 in-lb / 1.3 - 11.3 Nm
AUET/MTM-50-250(-DC)	5 - 50 in-lb / 0.56 - 5.65 Nm	25 - 250 in-lb / 2.8 - 28.3 Nm
AUET/MTM-50-500(-DC)	5 - 50 in-lb / 0.56 - 5.65 Nm	50 - 500 in-lb / 5.7 - 56.5 Nm
AUET/MTM-50-1000(-DC)	5 - 50 in-lb / 0.56 - 5.65 Nm	100 - 1,000 in-lb / 11.3 - 113 Nm
AUET/MTM-100-500(-DC)	10 - 100 in-lb / 1.13 - 11.3 Nm	50 - 500 in-lb / 5.7 - 56.5 Nm
AUET/MTM-100-1000(-DC)	10 - 100 in-lb / 1.13 - 11.3 Nm	100 - 1,000 in-lb / 11.3 - 113 Nm
AUET/MTM-100-1200(-DC)	10 - 100 in-lb / 1.13 - 11.3 Nm	120 - 1,200 in-lb / 13.6 - 135.6 Nm
AUET/MTM-100-1600(-DC)	10 - 100 in-lb / 1.13 - 11.3 Nm	160 - 1,600 in-lb / 18.1 - 180.8 Nm
AUET/MTM-100-2000(-DC)	10 - 100 in-lb / 1.13 - 11.3 Nm	200 - 2,000 in-lb / 22.6 - 226 Nm
AUET/MTM-250-1600(-DC)	25 - 250 in-lb / 2.82 - 28.2 Nm	160 - 1,600 in-lb / 18.1 - 180.8 Nm
AUET/MTM-250-1800(-DC)	25 - 250 in-lb / 2.82 - 28.2 Nm	180 - 1,800 in-lb / 20.3 - 203.4 Nm
AUET/MTM-250-2500(-DC)	25 - 250 in-lb / 2.82 - 28.2 Nm	250 - 2,500 in-lb / 28.2 - 282.5 Nm
AUET/MTM-500-2500(-DC)	50 - 500 in-lb / 5.7 - 56.5 Nm	250 - 2,500 in-lb / 28.2 - 282.5 Nm

* Add "-DC" to part numbers for data collecting models.

Data collecting models allow multiple files/tools/applications to be associated with torque data. Requires Tool Manager software.

Custom sizes are also available. Contact an Eagle Group Customer Service Associate for ordering options, (503) 254-6600, or toll free (800) 852-1368.

RUNDOWN FIXTURES

Features and Benefits

- Enables accurate and repeatable testing of pneumatic or electric power tools
- Mechanical Belleville system of bolt, nut or nut body, Belleville washers and main housing, 1/4" - 3/4" drive sizes, 10 in-lb - 1,200 ft-lb
- Fixtures can be ordered to simulate hard, medium, or soft joints

	ARDFA-XXXXHD ARDIA-XXXXHD	ARDFA-XXXHDS ARDIA-XXXHDS	ARDFA-XXXHDE ARDIA-XXXHDE	ARDFA-XXX ARDIA-XXX
Wear-Resistant Heavy-Duty	X			
Heavy-Duty, Fully Encapsulated		X		
Heavy-Duty, Encapsulated Washers			X	
Standard (Included w/analyzer)				X
Spline Drive				
Used in Conjunction with External Transducer				
ASTIS	X	X	X	X
AISI / AISF	X	X	X	X
ARTIS	X	X	X	X

*Spline drive feature provides rundown control when testing pulse tools. Custom sizes are also available. Contact an Eagle Group Customer Service Associate for ordering options, (503) 254-6600, or toll free (800) 852-1368.



AUDITOR RUNDOWN FIXTURES

To test power tools, pneumatic or electric, consistent rotational speed must be achieved. The joint rundown fixture/simulator provides the means by which the tool motor and spindle rotates freely at the start of the test cycle and then develops torque as rotation resistance increases as fastener/joint load increases. The linearity and consistency of the joint rundown fixtures/simulators vary greatly and the tool test data is a product of the variations in these rundown fixtures. Higher quality joint rundown fixtures produce torque data with less scatter.

ARDIA Models

Model*	Recommended Torque Range		Sq. Dr.
	Nm	in-lb	
ARDIA-10(HD)(HDE)(HDS)	0.13 - 1.13	1 - 10	1/4"
ARDIA-25(HD)(HDE)(HDS)	0.28 - 2.8	2.5 - 25	1/4"
ARDIA-50(HD)(HDE)(HDS)	0.56 - 5.6	5 - 50	1/4"
ARDIA-100(HD)(HDE)(HDS)	1.3 - 11.3	10 - 100	1/4"
ARDIA-150(HD)(HDE)(HDS)	1.7 - 16.9	15 - 150	1/4"
ARDIA-250(HD)(HDE)(HDS)	2.8 - 28.3	25 - 250	3/8"
ARDIA-350(HD)(HDE)(HDS)	4 - 40	35 - 350	3/8"
ARDIA-500(HD)(HDE)(HDS)	5.6 - 56.5	50 - 500	3/8"
ARDIA-750(HD)(HDE)(HDS)	8.5 - 84.7	75 - 750	3/8"
ARDIA-1000(HD)(HDE)(HDS)	11.3 - 113	100 - 113	3/8"

*Add "HD" to part numbers for wear resistant models. Add "HDS" to part numbers for fully encapsulated wear resistant models. Add "HDE" to part numbers for partial encapsulated wear-resistant models.

ARDFA Models

Model*	Recommended Torque Range		Sq. Dr.
	Nm	in-lb	
ARDFA-100(HD)(HDE)(HDS)	13.6 - 136	10 - 100	1/2"
ARDFA-150(HD)(HDE)(HDS)	20.4 - 204	15 - 150	1/2"
ARDFA-250(HD)(HDE)(HDS)	34 - 340	25 - 250	1/2"
ARDFA-500(HD)(HDE)(HDS)	67.8 - 678	50 - 500	3/4"
ARDFA-600(HD)(HDE)(HDS)	81.6 - 816	60 - 600	3/4"
ARDFA-750(HD)(HDE)(HDS)	101.7 - 1,017	75 - 750	3/4"

*Add "HD" to part numbers for wear resistant models. Add "HDS" to part numbers for fully encapsulated wear resistant models. Add "HDE" to part numbers for partial encapsulated wear-resistant models.

ERGO-ARM TOOL SUPPORT SYSTEMS



Ergo Arm Series torque reaction arms reduce operator fatigue by absorbing torque transfer from the tool to the operator. Optional tool mounts are available for pistol grip and angle style tools. They are available in single or parallel configurations. Parallel configurations maintain tool perpendicularity to the work piece throughout tool travel. By providing ergonomic support, Ergo-Arms increase productivity, consistency, and accuracy.



AD-D1098-PAC



AAD-D1098-SAC

PARALLEL ARM SERIES

AD-D1098-P, AD-D1098-PAC, AD-D1098-PACE

- Allows for freedom of movement
- Vertical adjustment eliminates cross-threading
- Fixtured tool increases repeatability
- Adjustable reach
- Available in air or oil cylinder models
- Electric tool mount standard on PACE model

SINGLE ARM SERIES

AD-D1098-S, AD-D1098-SAC

- Full tool rotation
- Allows for freedom of movement
- Adjustable reach
- Compatible with automatic screw feeder
- Available in air or oil cylinder models

Model*	Arm Style	Tool Mount	Reach		Capacity		Max. Torque*	
			in	mm	lb	kg	in-lb	Nm
AIR CYLINDER SERIES								
AD-D1098-SAC	Single	Air manifold	4 - 33	102 - 838	0 - 15	0 - 7	110	12
AD-D1098-PAC	Parallel	Air manifold	4 - 33	102 - 838	0 - 15	0 - 7	110	12
AD-D1098-PACE	Parallel	Electric	4 - 33	102 - 838	0 - 15	0 - 7	110	12
OIL CYLINDER SERIES								
AD-D1098-S	Single	Air manifold**	4 - 33	102 - 838	0 - 15	0 - 7	110	12
AD-D1098-P	Parallel	Air manifold	4 - 33	102 - 838	0 - 15	0 - 7	110	12

* Max torque allowed may be dependent on tool clutch type and joint rate
 ** For single arm electric tool mount, order EAP-202ED-KIT

SPECIAL FEATURES OF CLASSIC STYLE ERGO-ARM

Dual ball bearing joint construction for smoother movement and long life



Air regulator offers precision adjustment of resistance for perfect balance

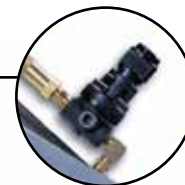

Unique upper rail adjustment allows true vertical approach to any fastener — no cross-threading



ERGO-ARM ACCESSORIES & LINEAR ARM

ERGO-ARM ACCESSORIES

- End-of-Arm Tooling options for the Ergo-Arm allow you to choose the style right for your application
- Tool holders permit the tool to swivel, rotate, swing, or twist. Heavy-duty construction can lock out any single, or combination of rotating, actions allowing only the motions required by your application
- End-of-Arm Tooling Brackets are simple to use. One Ergo-Arm can be used for more than one application

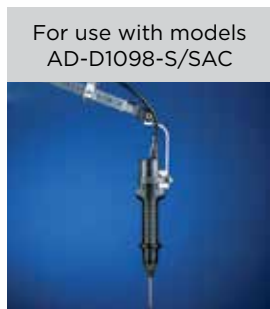

EAP-202ED-KIT
Electric Driver Tool Mount Kit

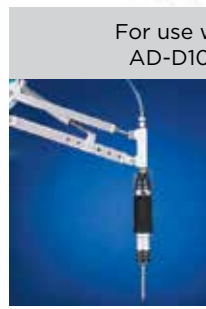

EAP-203-ASSY
Air Manifold Tool Mount Kit (Standard on parallel units)



EAP-202ASSY
Driver Tool Mount



EAA-04
Provides easy conversion of standard Ergo-Arms to the parallel style.

ALA & AFA SERIES LINEAR ARMS

Ergonomic support for electric and pneumatic tools reduces operator fatigue

The ALA Series (AIMCO Linear Arm) is constructed with precision linear slides and bearings for precise tool movements. The AFA Series (AIMCO Folding Arm) is configured with aluminum alloy beams connected by an elbow joint for working with tools in tight spaces.

ALA Series

- Constructed of lightweight aluminum
- Improves fastening quality and productivity
- Maintains perpendicularity of the tool to the application
- Absorbs torque reaction
- Counterbalances tool mass

AFA Series

- Includes all the features of the ALA Series
- Folding elbow joint allows for closer reach to post for tight workspaces



ALA Series

AFA Series with folding arm

Model*	Max Torque		Max Tool Weight		Reach		Tool Diameter	
	Nm	ft-lb	kg	lb	mm	in	mm	in
ALA SERIES LINEAR ARM								
ALA5-200	5	3.7	2	4.4	317 - 519	12.5 - 20.4	23 - 40	1.0 - 1.6
ALA15-200	15	11.1	3	6.6	317 - 519	12.5 - 20.4	23 - 40	1.0 - 1.6
ALA10-400	10	7.4	2	4.4	517 - 919	20.4 - 36.2	23 - 40	1.0 - 1.6
ALA40-300	40	29.5	3	6.6	417 - 719	16.4 - 28.3	32 - 47	1.3 - 1.9
ALA200-400	200	147.5	10	22	517 - 919	20.4 - 36.2		
ALA400-400	400	295	20	44	517 - 919	20.4 - 36.2		
AFA SERIES WITH FOLDING ARM								
AFA5-400	5	3.7	2	4.4	0 - 470	0 - 18.5	23 - 40	1.0 - 1.6
AFA15-400	15	11.1	3	6.6	0 - 470	0 - 18.5	23 - 40	1.0 - 1.6
AFA10-550	10	7.4	2	4.4	0 - 620	0 - 24.2	23 - 40	1.0 - 1.6

WORKSTATION COMPONENTS & ASSEMBLIES



COMPONENTS

TRACK

Steel with beige polyester finish. Use for vertical and horizontal workstation support.

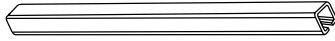

Part #	Length
30# Track	
AT3-3	3 ft track
AT3-4	4 ft track
AT3-6	6 ft track
AT3-9*	9 ft track
50# Track	
AT5-3	3 ft track
AT5-4	4 ft track
AT5-6	6 ft track
AT5-9*	9 ft track
AT5-12*	12 ft track

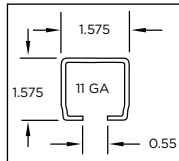
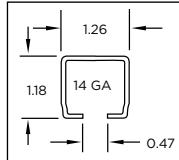

TRACK NUT (ATN-3/5)

Zinc plated steel. Use to attach accessories to track, as end stops, or to isolate rolling accessories.

- ATN-3 for 30 lb. track
- ATN-5 for 50 lb. track



END STOP (AES-3/5)

Zinc oxide finish. Use to prevent balancer trolley from "overtraveling" horizontal track.

- AES-3 for 30 lb. track
- AES-5 for 50 lb. track

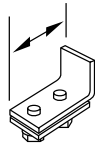

MOUNTING PLATE (AMP-5)

Black polyester finish. Use as a base to mount vertical uprights.

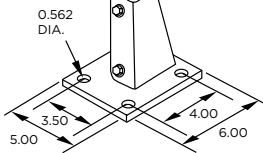

END CAP (AEP-3/5)

Black molded vinyl. Use to cap track ends for a professional finish.

- AEP-3 for 30 lb. track
- AEP-5 for 50 lb. track



ANGLE BRACKET (AB-3/5)

Black polyester finish. Use to mount horizontal track to vertical track.

- AB-3 for 30 lb. track
- AB-5 for 50 lb. track

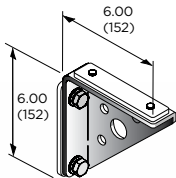

JOINT HANGER BRACKET (AJH-3/5)

Black polyester finish. Use to couple and hang end-to-end track.

- AJH-3 for 30 lb. track
- AJH-5 for 50 lb. track

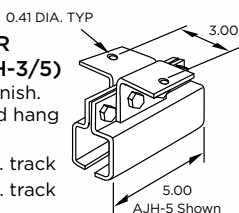

BALANCER TROLLEY (ABT-3/5)

Black polyester finish. Use as moving support for tool balancers, hose, and cable. Quality ball bearing wheels for long life and smooth tracking.

- ABT-3 for 30 lb track (1.00 dia)
- ABT-5 for 50 lb track (1.25 dia)

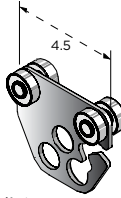

HANGER BRACKET (AHB-3/5)

Black polyester finish. Use to suspend track at right angle.

- AHB-3 for 30 lb. track
- AHB-5 for 50 lb. track

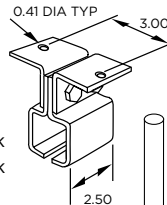

VERTICAL COLUMN (AVC-5*)

Beige polyester finish, 3" diameter x 9 ft upright steel column with welded base.

Use as floor mount for extra stability with jibs or workstation components.



HOSE/CABLE TROLLEY

Black polyester finish. Use for moving cable or hose festoon. Supports hose cable OD .60-.94.

- AIC-3-2 for 30 lb. track
- AIC-5-2 for 50 lb. track

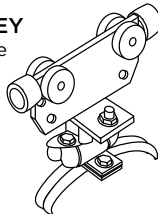

U-BOLTS (AUB-5)

Zinc plated steel. Use to secure boom bracket, or any flat metal plate, to AVC-5 (sold individually).



END CLAMP (AEC5-2)

Black polyester finish. Use as end stop with hose carrier for festoon. Cable/hose OD .60-.94.

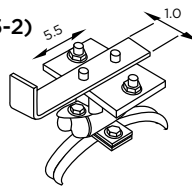

SUPPORT CLAMPS (ASC-3/5)

Black polyester finish. Use as additional support for track.

- ASC-3 for 30 lb. track
- ASC-5 for 50 lb. track

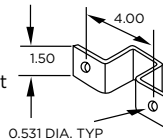

TOOL CLIP (SH-5)

Steel clip with safety latch. Use for tool attachment and as replacement clip for lightweight tool balancers. Length: 2.37"



ROLLING HANGER (ABT5-R)

Black polyester finish. Use as support for rolling track. Allows X/Y axis movement, includes ball bearing wheels.

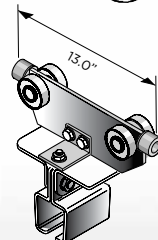

90° CONNECTOR FOR 3/8" HOSE (WSCH)

3/8" I.D. Brass. Use to provide stable transfer point from air line to tool. 90 degree connector attaches to ABT-5.

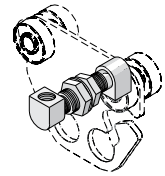

WALL AND FLOOR MOUNTED JIBS

3 FT. SWINGING JIB (AW3S)

3 FT. FIXED JIB (AW3F)

3 FT. SWINGING JIB FOR CHANNEL MOUNT (AJS3**)

Jibs are mounted to wall or beams to create free standing workstations. End stop, end cap, and balancer trolley included. Maximum weight: 30 lb.

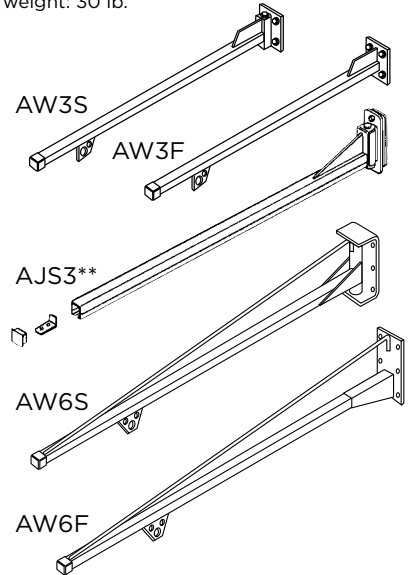

6 FT. SWINGING JIB (AW6S)

6 FT. FIXED JIB (AW6F)

Jibs can be wall mounted or attached to vertical column (AVC-5) to create a freestanding workstation. End stop, end caps, and balancer trolley are included. Maximum weight: 50 lb.

All complete assemblies are beige polyester finish and include balancer trolley, end caps, and end stops. Floor mounted assemblies are not able to ship via UPS.

When choosing a workstation system, remember...

Total weight capacities should include tool balancer, hose/cable, and tool/fixture. Units need to be supported vertically and horizontally every 6 ft.

** Additional freight may apply

** AJS3 Does not include balancer trolley

WORKSTATION COMPONENTS & ASSEMBLIES

**FLOOR MOUNTED
3 FT. SWINGING JIB*
(AW3FMS)**

**FLOOR MOUNTED
3 FT. FIXED JIB*
(AW3FMF)**

Maximum weight: 30 lb
Column height: 6 ft

**FLOOR MOUNTED
6 FT. SWINGING
JIB* (AW6FMS)**

**FLOOR MOUNTED
6 FT. FIXED JIB*
(AW6FMF)**

Maximum weight: 50 lb
Column height: 9 ft

*Units include end stop,
balancer trolley and
intermediate carrier.

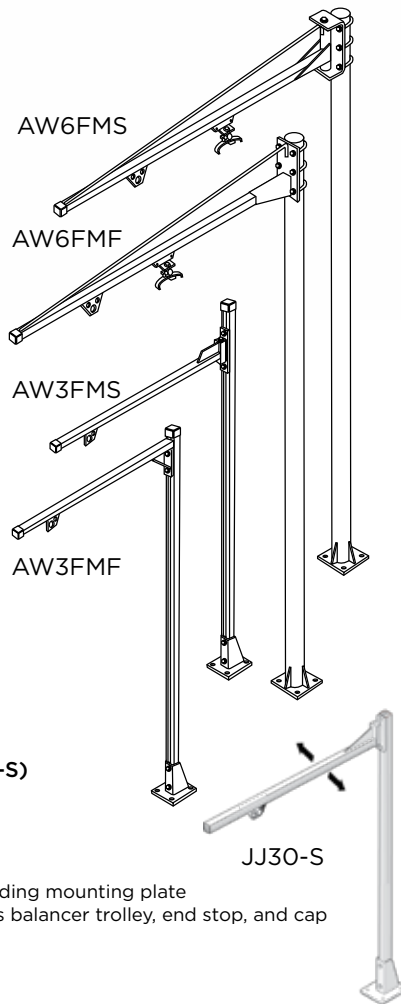

**BENCH MOUNTED
SWINGING JIB (JJ30-S)**

**BENCH MOUNTED
FIXED JIB (JJ30)**

Maximum weight: 30 lb
Column height: 48" including mounting plate
3 ft. swinging jib includes balancer trolley, end stop, and cap

AIMCO WORKSTATION KIT

**BENCH MOUNTED WORKSTATION
WITH TORQUE ARM (JJ30-TA**)**

- 5 lb. maximum weight (RPA-3 included)
- 5' column height including mounting plate
- 38" jib length (swinging)
- 15 ft-lb torque rating
- 3/8" NPT inlet
- 1/4" NPT outlet
- Beige polyester finish
- 1/4" braided air hose
- 21" maximum vertical arm travel

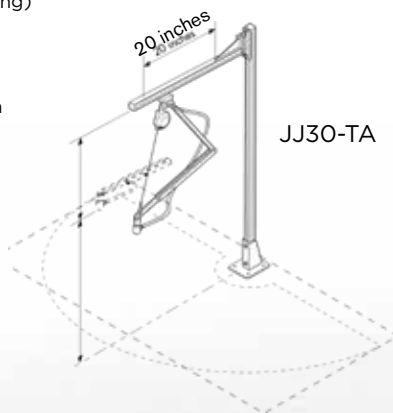

** Additional freight may apply
** For use with pneumatic tools only

CREATE A CUSTOM SUPPORT SYSTEM

- Organize work area to create a safe, productive working environment
- Reduce risk of injury to assembler by providing support for heavy tools
- Protect valuable tools, fixtures, and monitoring devices from damage by suspending them out of the way

AIMCO BASIC WORKSTATION KIT (ATW-50)



- 50 lb maximum weight capacity
- 48" uprights
- 36" extensions
- Table mounts included
- 6' tool rail with rolling trolley included
- All necessary hardware included

**TROLLEY MOUNTED TORQUE
ARM WITH 3-LB RETRACTOR
AND HOSE (FA-50-2*)**

Ergonomic arm absorbs torque reaction. Moves front to back along overhead jib.

(TA-50-2)
Moves side to side on overhead track.

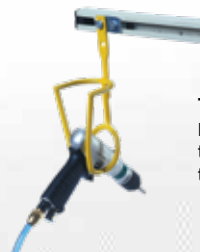
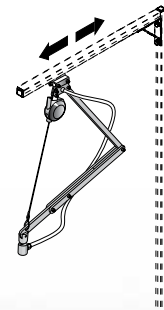

TOOL BASKET (21226)
Mounts easily to any work area to hold pistol and angle style tools.

Eagle Group can customize a workstation for you.
Contact an Eagle Group Customer Service Associate (503) 254-6600, or toll free (800) 852-1368.

TW SERIES BALANCERS

TW-0 and TW-00

- Gravity defying / “true balance”
- No tension buildup to cause worker fatigue
- Easy external direct drive tensioning
- 360° upper swivel
- Safety cable provision
- Tool clip included

TW-3 through TW-70

- Tapered drum allows “true balance” throughout cable travel
- Easy external direct drive tensioning
- Cast aluminum casing for durability
- Permanent lubrication
- 360° top swivel
- Enclosed spiral spring for added safety
- Safety chain provision (TW-3 through TW-15 models)
- Automatic safety lock plus manual drum lock (TW-22 through TW-70)



Model	Capacity		Anti-Gravity Capacity (lb)	Cable
	lb	kg		
TW-00	1.1 - 3.3	0.5 - 1.5	2.5 - 3	18" stranded steel cable 1/8" dia.
TW-0	1.1 - 3.3	0.5 - 1.5	2.5 - 3	3.3-ft stranded steel cable 1/8" dia..
TW-3	2.2 - 6.6	1 - 3	4.5 - 6	4.3-ft stranded steel cable 5/32" dia.
TW-5	5.5 - 11	2.5 - 5	8 - 10.5	4.3-ft stranded steel cable 5/32" dia.
TW-9	9.9 - 19.8	4.5 - 9	15 - 19	4.3-ft stranded steel cable 5/32" dia.
TW-15	19.8 - 33	9 - 15	26 - 32.5	4.3-ft stranded steel cable 5/32" dia.
TW-22	33 - 48.4	15 - 22	41 - 48	5-ft stranded steel cable 3/16" dia.
TW-30	48.4 - 66	22 - 30	58 - 65.5	5-ft stranded steel cable 3/16" dia.
TW-40	66 - 88	30 - 40	77.5 - 87.5	5-ft stranded steel cable 3/16" dia.
TW-50	88 - 110	40 - 50	100 - 109.5	5-ft stranded steel cable 3/16" dia.
TW-60	110 - 132	50 - 60	122 - 131	5-ft stranded steel cable 3/16" dia.
TW-70	132 - 154	60 - 70	144 - 153	5-ft stranded steel cable 3/16" dia.

RETRACTORS

RPA Series

- No tools needed to set tension
- 5 ft nylon coated steel cable
- Adjustable cable stop
- Tool clip included
- Model series supports weight range 0.5 - 5 lb
- Reinforced hanging bracket includes safety cable provision



RMA-L Series

- Steel housing with polyester finish
- Ratchet cable lock
- Permanently lubricated
- Tool clip included
- External tension adjustment
- Reinforced hanging bracket includes safety cable provision
- 8 ft of 3/32" diameter coated steel cable



Model	Capacity
RPA-1	0.5 - 1.5 lb 0.2 - 0.7 kg
RPA-2	1.5 - 3 lb 0.7 - 1.4 kg
RPA-3	3 - 5 lb 1.4 - 2.3 kg
RMA-7L	5 - 10 lb* 2.3 - 4.8 kg*
RMA-15L	10 - 15 lb* 4.5 - 6.8 kg*
RMA-20L	15 - 23 lb* 6.8 - 10.4 kg*

* With ratchet lock

ACCESSORIES

FRL FILTER/REGULATORS

AFRL STACKING FILTERS/REGULATORS

Stacking filter/regulator combinations provide air filtration and precise regulation in a single unit for easy mounting and installation.

- All models include L-mount bracket, gauge, and metal bowl shields
- Polycarbonate filter and lubricator bowls (metal bowls standard on AFRL-8)
- 25-micron filter included on all models
- Regulating range: 7 - 125 PSI
- Custom order upgrade items include metal bowl, 5 micron filter, semi-automatic filter drain, and reduced PSI range regulator. Contact an Eagle Group Customer Service Associate for more information, (503) 254-6600, or toll free (800) 852-1368



AFRL-2-C
AFRL-3-C



AFRL-3
AFRL-4
AFRL-8

Model	Port	Gauge Port	Flow Rate		Bowl Shield
			CFM	l/min	
AFRL-2	1/4"	1/8"	70	2,000	yes
AFRL-2-C	1/4"	1/8"	60	1,700	yes
AFRL-3	3/8"	1/4"	140	4,000	yes
AFRL-3-C	3/8"	1/4"	105	3,000	yes
AFRL-4	1/2"	1/4"	140	4,000	yes
AFRL-8	1"	1/4"	180	5,000	yes

Dimensions

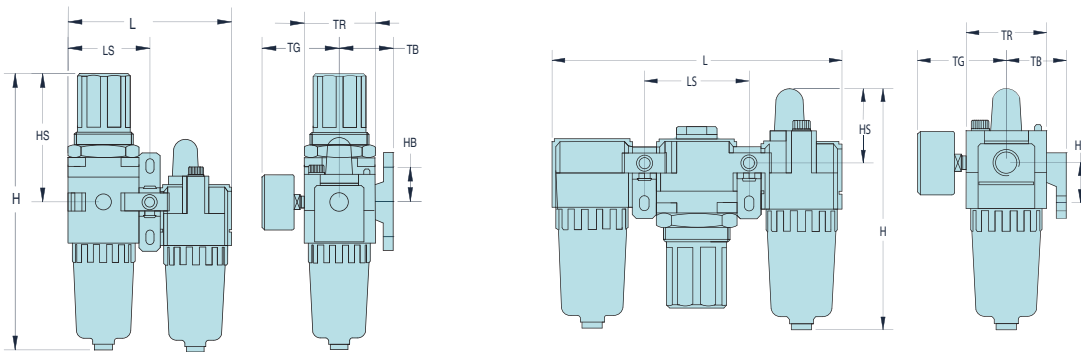

Model	H in/mm	HB in/mm	HS in/mm	L in/mm	LS in/mm	TB in/mm	TG in/mm	TR in/mm
AFRL-2	6.16 (156.5)	1.39 (35.3)	1.50 (38.1)	7.13 (181.1)	2.52 (64)	1.61 (41)	2.39 (60.7)	2.09 (53.1)
AFRL-2-C	8.31 (211.1)	1.38 (35.1)	3.64 (92.5)	4.61 (117.1)	2.30 (58.4)	1.61 (40.9)	2.39 (60.7)	2.09 (53.1)
AFRL-3	7.54 (191.5)	1.57 (40)	1.61 (40.9)	9.37 (238)	3.31 (84.1)	1.97 (50)	2.58 (65.5)	2.76 (70.1)
AFRL-3-C	10.31 (261.9)	1.57 (39.9)	4.41 (112)	6.06 (153.9)	3.03 (77)	1.97 (50)	2.58 (65.5)	2.76 (70.1)
AFRL-4	7.54 (191.5)	1.57 (40)	1.61 (40.9)	9.37 (238)	3.31 (84.1)	1.97 (50)	2.58 (65.5)	2.76 (70.1)
AFRL-8	10.69 (271.5)	1.97 (50)	1.89 (48)	11.81 (300)	4.13 (104.9)	2.75 (69.9)	2.97 (75.4)	3.54 (89.9)

POLYURETHANE AIR HOSE

Single Air Hose Assemblies (Coiled)

- Durable Polyurethane is chemical resistant and lightweight, and provides excellent recoil memory and maximum flexibility
- Available in transparent hose color (opaque also available)
- Assemblies for coiled hose include reusable swivel fitting. Straight hose available with or without fittings
- Working temperature: -104° F to 175° F

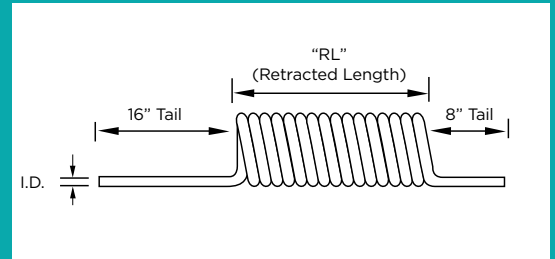

Model	Size (O.D. x I.D. x Length)	Retracted Length	Working Pressure	NPT Fittings
ASH-250C-10MSZ	3/8" x 1/4" x 10'	7"	100 psi	1/4"
ASH-250C-15MSZ	3/8" x 1/4" x 15'	9-1/2"	100 psi	1/4"
ASH-250C-25MSZ	3/8" x 1/4" x 25'	15-1/2"	100 psi	1/4"
ASH-375C-15MSZ	9/16" x 3/8" x 15'	10"	100 psi	3/8"
ASH-375C-25MSZ	9/16" x 3/8" x 25'	14"	100 psi	3/8"
ASH-500C-15MSZ	3/4" x 1/2" x 15'	13"	100 psi	1/2"
ASH-500C-25MSZ	3/4" x 1/2" x 25'	23"	100 psi	1/2"

Custom length coil assemblies and special colors available in minimum order quantities. Contact an Eagle Group Customer Service Associate, (503) 254-6600, or toll free (800) 852-1368.

Straight Air Hose

- Sold per foot
- For full-reel pricing, contact an Eagle Group Customer Service Associate, (503) 254-6600, or toll free (800) 852-1368.



Model	I.D.
ASH-375Z	3/8"
ASH-500Z	1/2"

RUBBER HOSE

- Designed for use in a wide range of industrial, construction, and agricultural applications
- Constructed of high grade, reinforced EPDM synthetic rubber
- Working temperature: -40° F to 190° F



I.D.	O.D.	Length	Working Pressure	Weight
3/16"	0.44"	10 ft	200 psi	0.8 lb
1/4"	0.5"	10 ft	200 psi	0.9 lb
5/16"	0.58"	10 ft	200 psi	1.2 lb
3/8"	0.67"	10 ft	200 psi	1.5 lb
1/2"	0.81"	10 ft	200 psi	2.0 lb
5/8"	0.97"	10 ft	200 psi	2.7 lb
3/4"	1.12"	10 ft	200 psi	3.4 lb

Custom lengths available. Contact an Eagle Group Customer Service Associate, (503) 254-6600, or toll free (800) 852-1368.

AIR LINE ACCESSORIES

BRASS QUICK COUPLERS

Manual ball couplers designed for use with ergonomic twist plugs. Brass with nitrile seals, rated to 300 PSI, from -40° to +250° F.

Model	Description
B23	1/4" NPT F x 1/4" QC
B23E	1/4" NPT F x 3/8" QC
B25	3/8" NPT F x 3/8" QC



MINI AIR GAUGE SWIVEL JOINT KITS

- Bi-directional 360° rotation
- Keeps air hose straight and untwisted
- Decreases operator fatigue



Model	Inlet	Weight	Max PSI	Tool CFM
7021AG	1/4" NPT	3 oz	Up to 125	25
7041AG	3/8" NPT	3 oz	Up to 125	50

SWIVEL AIR FITTINGS

For use with most portable air tools, including grinders, drills, screwdrivers, buffers, sanders, staple guns, and more. Rotates 360° for awkward angles.



Model	Inlet	Weight	Max PSI	Tool CFM
7021	1/4" NPT	3 oz	Up to 125	25
7041A	3/8" NPT	11 oz	Up to 125	50
7051	1/2" NPT	7 oz	Up to 125	60

ERGONOMIC TWIST PLUGS



These unique, ergonomically designed hose fittings provide 360° rotation and 35° angled rotation in any direction.

- Two rotation points prevent kinking of air hose
- Design ensures full air pressure flow
- Rotating joint has polyurethane dust cover
- Heavy-duty construction

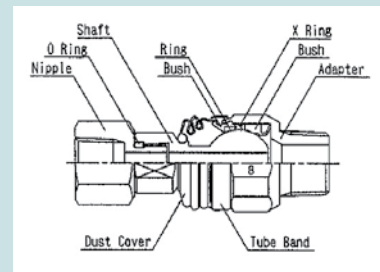

Model	Description
TS-30NP-2NPT	3/8" NPT Female x 1/4" NPT Male
TS-20NP-2NPT	1/4" NPT Female x 1/4" NPT Male
TS-20US-2NPT	1/4" US Plug x 1/4" NPT Male
TS-30US-3NPT	3/8" US Plug x 3/8" NPT Male

AIR LINE FITTINGS

Model	Description
375-RZ	1/4" NPT Rigid Fitting
250-RZ	1/4" NPT Swivel Fitting
375-SZ	3/8" NPT Rigid Fitting
250-SZ	3/8" NPT Swivel Fitting
500-SZ	1/2" NPT Swivel Fitting

STANDARD FASTENER TOOLS

Connect your tool to the application with Bits, Sockets, and Nutsetters from AIMCO.

AIMCO has assembled a complete package of commonly used screwdriver bits and nutsetters. Our goal is to supply you with the highest quality bits and nutsetters for your fastener needs. Whether you're in electronics, aerospace, automotive, or general industry, AIMCO has the bits and nutsetters to fit your needs.

MAG-O-NETS: A REVOLUTIONARY WAY TO CONVERT STANDARD BITS TO MAGNETIC BITS



- Easy, cost effective alternative to traditional magnetic bit holder and insert bit combination
- Improves torque transfer by eliminating “wobble effect”
- Easily adjust magnetic attraction by moving Mag-O-Net collar closer to or further from fastener
- Fits virtually any standard screwdriver bit
- Reusable and interchangeable — once a bit is worn out, simply remove your Mag-O-Net and slide it onto the next bit
- Lifetime guarantee on magnetic attraction

Part #	ID	OD	L
AM1/4Z	7 mm	19 mm	10 mm
AM5Z	6 mm	17.5 mm	10 mm
AM3/16Z	3/16 in	17.5 mm	10 mm

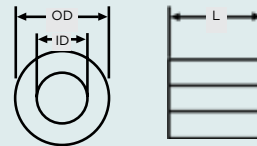

MARKER SOCKETS

Marker Sockets paint the bolt head at the same time the torque is checked. Sockets are designed to your specification.

- Unit consists of a marker socket, an ink cartridge, a spring, and the cartridge cap
- Cartridge can be inserted/taken off easily for ink management
- Easily replaceable paint point
- Can be used with either oil-based or water-based inks
- When ordering, provide dimensions shown. To order, contact an Eagle Group Customer Service Associate (503) 254-6600, or toll free (800) 852-1368



Socket

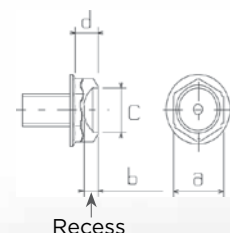
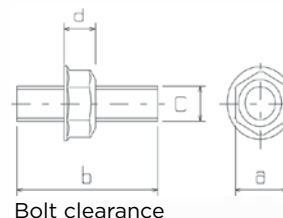
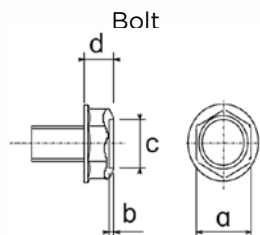

ACCESSORIES

BITS & SOCKETS

IMPACT SOCKETS

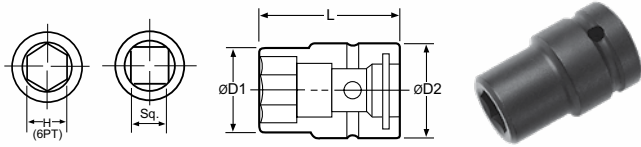

Part #	Hex	D1		D2		L	
		mm	in	mm	in	mm	in

3/8" Square Drive							
METRIC SAE	A31/4	1/4"	10	0.39	19	0.75	34 1.34
	A35/16	5/16"	12	0.47	19	0.75	34 1.34
	A33/8	3/8"	15	0.59	19	0.75	34 1.34
	A306	6 mm	10	0.39	19	0.75	34 1.34
	A307	7 mm	13	0.49	20	0.79	32 1.26
	A308	8 mm	14	0.55	20	0.79	32 1.26

3/8" Square Drive, Deep							
	A307-2	7 mm	13	0.49	20	0.79	50 1.97
	A307-2.75	7 mm	13	0.49	20	0.79	70 2.76
	A308-2	8 mm	14	0.55	20	0.79	50 1.97

3/8" Square Drive, Magnetic							
METRIC SAE	A31/4MP	1/4"	10	0.39	19	0.75	34 1.34
	A35/16MP	5/16"	12	0.47	19	0.75	34 1.34
	A33/8MP	3/8"	15	0.59	19	0.75	34 1.34
	A308MP	8 mm	14	0.55	20	0.79	32 1.26
	A310MP	10 mm	17	0.65	20	0.79	32 1.26
	A311MP	11 mm	17	0.65	19	0.75	34 1.34

1/2" Square Drive							
METRIC SAE	A43/8	3/8"	16	0.63	25	0.98	38 1.50
	A47/16	7/16"	18	0.69	25	0.98	38 1.50
	A41/2	1/2"	19	0.75	25	0.98	50 1.97
	A408	8 mm	16	0.61	25	0.98	40 1.58
	A409	9 mm	16	0.63	25	0.98	40 1.58
	A410	10 mm	18	0.69	25	0.98	40 1.58

Part #	Hex	D1		D2		L	
		mm	in	mm	in	mm	in

1/2" Square Drive, Deep							
METRIC SAE	A43/8-3.25	3/8"	17	0.67	25	0.98	82 3.23
	A47/16-3.25	7/16"	19	0.73	25	0.98	82 3.23
	A41/2-3.25	1/2"	22	0.85	25	0.98	82 3.23
	A410-2	10 mm	18	0.69	25	0.98	50 1.97
	A410-3	10 mm	18	0.69	25	0.98	75 2.95
	A411-3.25	11 mm	19	0.73	25	0.98	82 3.23

1/2" Square Drive, Magnetic							
	A408MP	8 mm	16	0.61	25	0.98	40 1.58
	A410MP	10 mm	18	0.69	25	0.98	40 1.58
	A412MP	12 mm	21	0.81	25	0.98	40 1.58

3/4" Square Drive							
METRIC SAE	A611/16	11/16"	30	1.18	44	1.73	50 1.97
	A63/4	3/4"	32	1.26	44	1.73	50 1.97
	A613/16	13/16"	35	1.38	44	1.73	50 1.97
METRIC SAE	A614	14 mm	24	0.95	38	1.50	55 2.17
	A616	16 mm	27	1.06	44	1.73	50 1.97
	A617	17 mm	30	1.18	38	1.50	55 2.17

3/4" Square Drive, Deep							
METRIC SAE	A611/16-4	11/16"	31	1.22	44	1.73	100 3.94
	A63/4-4	3/4"	33	1.30	44	1.73	100 3.94
	A613/16-4	13/16"	36	1.42	44	1.73	100 3.94
METRIC SAE	A617-4	17 mm	31	1.22	44	1.73	100 3.94
	A618-4	18 mm	32	1.26	44	1.73	100 3.94
	A619-4	19 mm	33	1.30	38	1.50	100 3.94

1" Square Drive							
METRIC SAE	A87/8	7/8"	37	1.46	54	2.13	59 2.32
	A815/16	15/16"	38	1.50	54	2.13	59 2.32
	A81	1"	41	1.61	54	2.13	59 2.32
	A817	17 mm	31	1.22	50	1.97	63 2.48
	A819	19 mm	33	1.30	50	1.97	63 2.48
	A821	21 mm	37	1.46	50	1.97	63 2.48

ANTI-MARRING SOCKETS

AIMCO's anti-marring sockets have a protective resin cover that spins freely, preventing damage to application surfaces, and protecting fingers.

To order sockets specific to your application, contact an Eagle Group Customer Service Associate (503) 254-6600, or toll free (800) 852-1368



CV Series



CVF Series



CVF Series with Bit Attachment



Allen Sockets

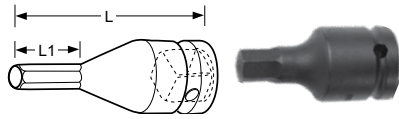

Part #	Hex	L1		L	
		mm	in	mm	in

3/8" Square Drive

A31/4C	1/4"	10	0.39	42	1.65
A304C	4 mm	10	0.39	42	1.65

1/2" Square Drive

A41/4C	1/4"	25	0.98	50	1.97
A405C	5 mm	25	0.98	50	1.97

Universal Sockets

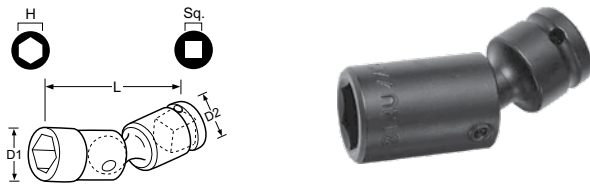

Part #	Hex	D1		D2		L	
		mm	in	mm	in	mm	in

3/8" Square Drive

A310U	10 mm	16	0.63	20	0.79	55	2.17
A311U	11 mm	16	0.63	20	0.79	60	2.36

1/2" Square Drive

A412U	12 mm	20.5	0.81	25	0.98	70	2.76
A413U	13 mm	19	0.75	24	0.95	70	2.76

Extensions

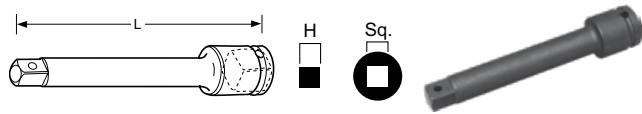

Part #	Sq. Drive		L		D	
	Hex	mm	mm	in	mm	in

A375E	3/8"	3/8"	75	2.95	20	0.79
A405E	1/2"	1/2"	51	2.01	30	1.18
A610E	3/4"	3/4"	100	3.94	44	1.73
A810E	1"	1"	102	4.02	54	2.13
A1220E	1-1/4"	1-1/4"	200	7.87	60	2.36
A1418E	1-1/2"	1-1/2"	178	7.01	84	3.31
A2426E	2-1/2"	2-1/2"	264	10.39	137	5.39

Socket Adapters



Part #	Female	Male	D		L	
	Sq. Drive	Sq. Drive	mm	in	mm	in
A302A	3/8"	1/4"	22	0.87	35	1.38
A403A	1/2"	3/8"	25	0.98	37	1.46
A504A	5/8"	1/2"	35	1.38	47	1.46
A604A	3/4"	1/2"	38	1.50	53	2.09
A806A	1"	3/4"	50	1.97	70	2.76
A128A	1-1/4"	1"	60	2.36	76	2.99
A#508A	Spline #5	1"	60	2.36	90	3.54

Nutsetters

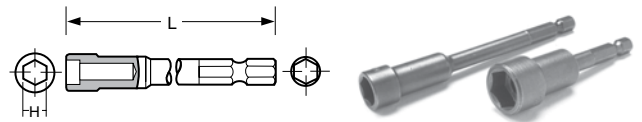

Part #	Hex	L	
		mm	in
A3B1/4-2	1/4"	50	1.97
A3B1/4-2.5	1/4"	63	2.50
A3B5/16-2	5/16"	50	1.97
A3B5/16-2.5	5/16"	63	2.50
A3B3/8-2	3/8"	50	1.97
A3B3/8-2.5	3/8"	63	2.50
A3B05-2.75	5 mm	70	2.76
A3B55-1.2	5.5 mm	30	1.18
A3B55-2.75	5.5 mm	70	2.76
A3B55-4	5.5 mm	100	3.94
A3B06-2.75	6 mm	70	2.76
A3B07-1.2	7 mm	30	1.18
A3B07-2	7 mm	50	1.97
A3B07-2.75	7 mm	70	2.76
A3B07-4	7 mm	100	3.94
A3B08-1.2	8 mm	30	1.18
A3B08-2	8 mm	50	1.97
A3B08-2.75	8 mm	70	2.76
A3B08-4	8 mm	100	3.94
A3B08-6	8 mm	150	5.91
A3B08-8	8 mm	200	7.87
A3B09-2.75	9 mm	70	2.76
A3B09-4	9 mm	100	3.94
A3B10-1.2	10 mm	30	1.18
A3B10-2	10 mm	50	1.97
A3B10-2.75	10 mm	70	2.76
A3B11-2.75	11 mm	70	2.76
A3B12-1.2	12 mm	30	1.18
A3B13-2.75	13 mm	70	2.76
A3B14-2.75	14 mm	70	2.76
A3B16-2.75	16 mm	70	2.76
A3B17-2.75	17 mm	70	2.76

BITS & SOCKETS

Quick Change Chucks

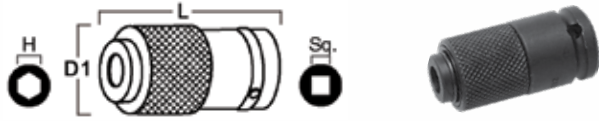

Part #	Sq. Drive	Hex	D1		L	
			mm	in	mm	in
ADC-2S	1/4"	1/4"	19	0.75	38	1.50
ADC-3S	3/8"	1/4"	20	0.79	42	1.65
ADC-4S	1/2"	1/4"	19	0.75	46	1.81
ADC-3SH7/16Z	3/8"	7/16"	25	0.98	46	1.81
ADC-4SH7/16Z	1/2"	7/16"	33	1.30	55	2.17

Phillips Insert Bits



Part No	Point Size	mm	L	in
A38S2-1	2	25		0.98
A38S3-1	3	25		0.98

Phillips Single-Ended Power Bits

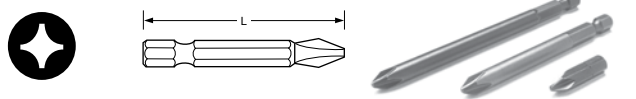

Part #	Point Size	mm	L	in
A3S0-2	0	50		1.97
A3S1-2	1	50		1.97
A3S1-2.75	1	70		2.76
A3S1-3	1	75		2.95
A3S1-3.5	1	90		3.54
A3S1-4	1	100		3.94
A3S1-6	1	150		5.91
A3S2-1.2	2	30		1.18
A3S2-1.6	2	40		1.57
A3S3-2	3	50		1.97
A3S3-2.75	3	70		2.76

Square Recess Bits

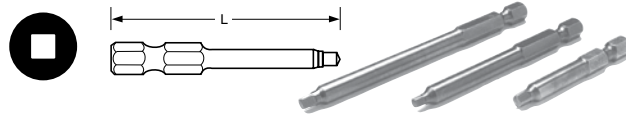

Part No	Point Size	Nominal Square Size	mm	L	in
A3R1/8-2.75	2	1/8"	70		2.76
A3R9/64-2.75	3	9/64"	70		2.76

Square Recess Insert Bits

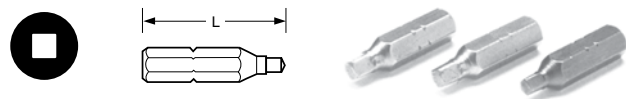

Part No	Point Size	Nominal Square Size	mm	L	in
A38R1/8-1	2	1/8"	25		0.98
A38R9/64-1	3	9/64"	25		0.98

Slotted Insert Bits

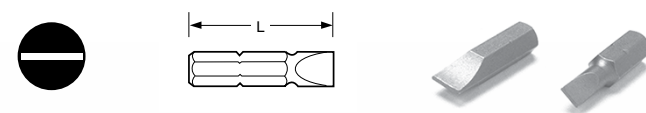

Part No	Screw Size	L	Blade Thickness	Blade Width	
		mm	in		
A38M8-1	8	25	0.98	0.04	0.25
A38M10-1	10	25	0.98	0.05	0.28

Phillips Double-Ended Power Bits

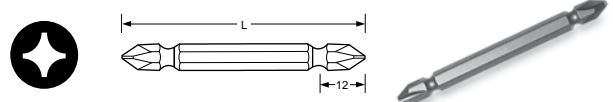

Part #	Size	mm	L	in
A3W1-3	1	75		2.94
A3W1-4	1	100		3.94
A3W2-2	2	50		1.97
A3W2-3	2	75		2.94
A3W2-4	2	100		3.94
A3W2-6	2	150		5.91
A3W2-8	2	200		7.87
A3W2-10	2	250		9.84
A3W2-12	2	300		11.81
A3W3-2	3	50		1.97
A3W3-3	3	75		2.94
A3W3-4	3	100		3.94
A3W3-6	3	150		5.91
A3W3-8	3	200		7.87

BITS & SOCKETS

Slotted Power Bits

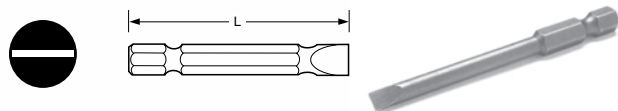

Part #	Screw Size	mm	L in	Blade Thickness	Blade Width
A3M8-3	8	75	2.95	0.04	0.28
A3M10-3	10	75	2.95	0.05	0.31

Torx Power Bits

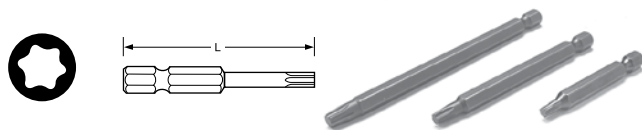

Part #	Torx Size	mm	L in
A3T6-2	T6	50	1.97
A3T7-2	T7	50	1.97
A3T7-2.75	T7	70	2.76
A3T7-3.5	T7	90	3.54
A3T7-6	T7	150	5.91
A3T8-2	T8	50	1.97
A3T9-2.75	T9	70	2.76

Bit Holders



Part #	MM	L IN
1/4" Hex, Magnetic		
A3BHM-3	75	2.94
A3BHM-4	100	3.94
A3BHM-6	150	5.91
A3BHM-8	200	7.87
A3BHM-10	250	9.84

Bit and Nutsetter Part Number Nomenclature

Precedes Part Number

BITS		A7	7/16 Power Drive
A3S	Phillips® Power Drive	AS	Electric Type Phillips®
A3W	Double Ended Phillips®	AM	Electric Type Slotted
A38S	Phillips® Insert	ATW	Electric Type Tri-Wing®
A39S	Phillips® Insert Reduced Nose	AT	Electric Hios Type Torx®
A3M	Slotted Power Drive	A26S	Electric Driver Phillips®
A38M	Slotted Insert	A26M	Electric Driver Slotted
A3MT	Slotted Power Drive Reduced Nose	A26C	Electric Driver Allen Socket Head
A3C	Allen Socket Head Power Drive	A3BHM	Insert Bit Holder (Magnetic Type)
A38C	Allen Socket Head Insert	A3BHD	Insert Bit Holder (Non Magnetic)
A3R	Square Recess Power Drive	NUTSETTERS	
A3RT	Square Recess Turned Down (Power)	A3B	Nutsetter
A38R	Square Recess Insert	A3BMP	Magnetic (MP) Pressed Type
A3T	Torx® Power Drive	A3BMS	Magnetic (MS) Spring Loaded
A38T	Torx® Insert	A3BMT	Magnetic (MT) Tube Type
A3TS	Torq-Set® Power Drive	A3BU	Universal Nutsetter
A38TS	Torq-Set® Insert	MAG-O-NETS	
A3TA	Triangle Power Drive	AM	AIMCO Mag-O-Net®
A3TW	Tri-Wing® Power Drive		
A38TW	Tri-Wing® Insert		

Contained within Part Number

Bits		ACRB	ACR® 4x4 Both Install and Remove
PZ	Pozidriv®	E4	Electric 4mm diameter
PZACR	Pozidriv® ACR®	E5	Electric 5mm diameter
SDV	Supadriv®	RS	Reduced Shank
TR	Torx® Tamper Resistant		
ACRI	ACR® Installation		
ACR	ACR® Remove		

Additional types and sizes of fastener tools, as well as custom parts, are available upon request. Contact an Eagle Group Customer Service Associate at (503) 254-6600, or toll free (800) 852-1368.

RESOURCES

RESOURCES

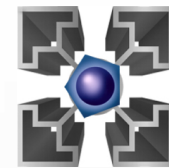











Eagle Group: Power Tool Solutions

For more information on tools, accessories, service, and training, contact your Eagle Group Customer Service Associate at (503) 254-6600 or (800) 852-1368.

Fraction • Decimal • Metric Conversions (to .32)

Fraction	Decimal	mm	Fraction	Decimal	mm	Fraction	Decimal	mm	Fraction	Decimal	mm
1/32	.03125	.7938	9/32	.28125	7.1438	17/32	.53125	13.4938	25/32	.78125	19.8438
1/16	.0625	1.5875	5/16	.3125	7.9375	9/16	.5625	14.2875	13/16	.8125	20.6375
3/32	.09375	2.3812	11/32	.34375	8.7312	19/32	.59375	15.0812	27/32	.84375	21.4312
1/8	.125	3.175	3/8	.375	9.525	5/8	.625	15.875	7/8	.875	22.225
5/32	.15625	3.9688	13/32	.40625	10.3188	21/32	.65625	16.6688	29/32	.90625	23.0188
3/16	.1875	4.7625	7/16	.4375	11.1125	11/16	.6875	17.4625	15/16	.9375	23.8125
7/32	.21875	5.5562	15/32	.46875	11.9062	23/32	.71875	18.2562	31/32	.96875	24.6062
1/4	.25	6.35	1/2	.5	12.7	3/4	.75	19.05	1	1.0	25.4

Thread Size to Hex Size

 Metric Bolt Size	 Socket Hex Size (mm)	 Metric Bolt Size	 Socket Hex Size (mm)	 Metric Bolt Size	 Socket Hex Size (mm)	 SAE Bolt Size	 Socket Hex Size (in)	 UNC Bolt Size	 Socket Hex Size (in)
M 2	4	M 14	21	M 52	80	1/4	7/16	1/4	7/16
M 2.3	4.5	(M 14)	22	M 56	85	5/16	1/2	5/16	1/2
M 2.6	5	M 16	24	M 60	90	3/8	9/16	3/8	9/16
M 3	5.5	M 18	27	M 64	95	7/16	5/8	7/16	11/16
M 3.5	6	M 20	30	M 68	100	1/2	3/4	1/2	3/4
M 4	7	(M 22)	32	M 72	105	9/16	7/8	9/16	7/8
M 5	8	M 22	34	M 76	110	5/8	15/16	5/8	15/16
(M 5-6)	9	M 24	36	M 80	115	3/4	1-1/16	3/4	1-1/8
M 6	10	M 27	41	M 85	120	7/8	1-1/4	7/8	1-5/16
M 7	11	M 30	46	M 90	130	1-1/8	1-7/16	1	1-1/2
M 8	13	M 33	50	M 95	135	1-1/4	1-13/16	1-1/8	1-11/16
(M 8)	14	M 36	55	M 100	145	1-3/8	2	1-1/4	1-7/8
M 10	16	M 39	60	M 105	150	1-1/2	2-3/16	1-3/8	2-1/16
(M 10)	17	M 42	65	M 110	155			1-1/2	2-1/4
M 12	18	M 45	70	M 115	165			1-3/4	2-5/8
(M 12)	19	M 48	75	M 120	170			2	3
								2-1/4	3-3/8
								2-1/2	3-3/4

Torque Conversion Factors

Units to be Converted	SAE			METRIC			INTERNATIONAL SYSTEM - S.I.		
	ozf-in	lbf-in	lbf-ft	gf-cm	kgf-cm	kgf-m	mNm	cNm	Nm
1 ozf-in	1	0.0625	0.005	72	0.072	0.0007	7.062	0.706	0.007
1 lbf-in	16	1	0.083	1152.1	1.152	0.0115	113	11.3	0.113
1 lbf-ft	192	12	1	13826	13.83	0.138	1356	135.6	1.356
1 gf-cm	0.014	0.0009	0.00007	1	0.001	0.00001	0.098	0.01	0.0001
1 kgf-cm	13.89	0.868	0.072	1000	1	0.01	98.07	9.807	0.098
1 kgf-m	1389	86.8	7.233	100000	100	1	9807	980.7	9.807
1 mN-m	0.142	0.009	0.0007	10.2	0.01	0.0001	1	0.1	0.001
1 cN-m	1.42	0.088	0.007	102	0.102	0.001	10	1	0.01
1 N-m	141.6	8.851	0.738	10197	10.20	0.102	1000	100	1

RESOURCES

MODEL #	PAGE	MODEL #	PAGE	MODEL #	PAGE	MODEL #	PAGE	MODEL #	PAGE
A									
AB-3	60	APTH-14OE1	54	ATC-10	55	EPTS-33023P-25Q	33	SPC-A21625Q	35
AB-3/5	60	APTH-14OE13	54	ATC-25	55	EPTS-34008-25Q	33	SPC-A21638	35
AB-5	60	APTH-14OE14	54	ATC-100	55	EPTS-34008P-25Q	33	SPC-A23038	35
ABT-3	60	APTH-14OE15	54	ATC-150F	55	EPTS-34015-25Q	33	SPC-A23538	35
ABT-5	60	APTH-14OE16	54	ATC-250	55	EPTS-34015P-25Q	33	SPC-A25038	35
ABT5-R	60	APTH-14OE17	54	ATC-250F	55	EPTS-34021-25Q	33	SPC-A27038	35
AD-D1098-P	58	APTH-14OE18	54	ATC-500	55	EPTS-34021P-25Q	33	SPC-A210050	35
AD-D1098-PAC	58	APTH-14OE19	54	ATC-500F	55	EPTS-35005P-25Q	33	SPC-B218LI	36
AD-D1098-PACE	58	APTH-14OE21	54	ATC-750	55	EPTS-35008P-25Q	33	SPC-B218LI-HC	36
AD-D1098-S	58	APTH-14OE22	54	ATC-750F	55	EPTS-35017P-25Q	33	SPC-C218-19	36
AD-D1098-SAC	58	APTH-14OE24	54	ATC-1800	55	EPTS-N34003-25	33	SPC-P2325Q	35
AEC5-2	60	APTH-14OE25	54	ATN-3	60	EPTS-N34003-38	33	SPC-P2625Q	35
AEP-3	60	APTH-14OE27	54	ATN-5	60			SPC-P2925Q	35
AEP-5	60	APTH-14OE30	54	ATW-50	61	F			
AES-3	60	APTH-14OE32	54	AUB-5	60	FA-50-2	61	SPC-P-HL-LH	36
AES-5	60	APTH-14OE34	54	AUET-10(-DC)	56			SPC-P-HL-RH	36
AFRL-4	63	APTH-14OE36	54	AUET-50(-DC)	56	G			
AFA5-400	59	APTH-14OE38	54	AUET-0100(-DC)	56	GAB41-A60-DW	11	SPC-QC	36
AFA10-550	59	APTH-14OE41	54	AUET-250(-DC)	56	GDB31-E18-CE	12		
AFA15-400	59	APTH-14OE118	54	AUET-500(-DC)	56	GDB31-E18-CW	4, 12	T	
AFRL-2	63	APTH-14OE138	54	AUET-1000(-DC)	56	GTB31-A12-DW	13	TA-50-2	61
AFRL-2-C	63	APTH-14RE32	54	AUET-1200(-DC)	56	GTB41-A60-DW	13	TS-20NP-2NPT	65
AFRL-3	63	APTH-14RT34	54	AUET-1800(-DC)	56	GTB41-A60-DW-6	13	TS-20US-2NPT	65
AFRL-3-C	63	APTH-14RT50	54	AUET/MTM-10-100(-DC)	56	GTB41-A85-DW	13	TS-30NP-2NPT	65
AFRL-8	63	APTH-14SD50	54	AUET/MTM-050-25	56	GVB51P-V60-DW	14	TS-30US-3NPT	65
AHB-3	60	APTW-25	54	AUET/MTM-50-250(-DC)	56	GVB51P-V60-DW-6	14	TW-00	62
AHB-5	60	APTW-50	54	AUET/MTM-50-500(-DC)	56	GVB51P-V85-DW	14	TW-0	62
AIC3-2	60	APTW-100	54	AUET/MTM-050-600(-DC)	56			TW-3	62
AIC5-2	60	APTW-150	54	AUET/MTM-50-1000(-DC)	56			TW-5	62
AJH-3	60	APTW-200	54	AUET/MTM-0100-050(-DC)	56			TW-9	62
AJH-5	60	APTW-340	54	AUET/MTM-100-500(-DC)	56			TW-15	62
AJS3	60	ARDFA-100(HD)(HDE)(HDS)	57	AUET/MTM-100-1000(-DC)	56			TW-22	62
ALA5-200	59	ARDFA-150(HD)(HDE)(HDS)	57	AUET/MTM-100-1200(-DC)	56			TW-30	62
ALA10-400	59	ARDFA-250(HD)(HDE)(HDS)	57	AUET/MTM-100-1600(-DC)	56			TW-40	62
ALA15-200	59	ARDFA-500(HD)(HDE)(HDS)	57	AUET/MTM-100-2000(-DC)	56			TW-50	62
ALA40-300	59	ARDFA-600(HD)(HDE)(HDS)	57	AUET/MTM-250-1600(-DC)	56			TW-60	62
ALA200-400	59	ARDFA-750(HD)(HDE)(HDS)	57	AUET/MTM-250-1800(-DC)	56			TW-70	62
ALA400-400	59	ARDIA-10(HD)(HDE)(HDS)	57	AUET/MTM-250-2500(-DC)	56				
AMP-5	60	ARDIA-25(HD)(HDE)(HDS)	57	AUET/MTM-500-2500(-DC)	56			U	
APTH-12ADP	54	ARDIA-50(HD)(HDE)(HDS)	57	AVC-5	60	RMA-7L	62	UG-60S-29	51
APTH-12BLANK	54	ARDIA-100(HD)(HDE)(HDS)	57	AW3F	60	RMA-15L	62	UG-65-EBL-ASSY	51
APTH-12OE7	54	ARDIA-150(HD)(HDE)(HDS)	57	AW3FMF	61	RMA-20L	62	UG-1250LM	51
APTH-12OE8	54	ARDIA-250(HD)(HDE)(HDS)	57	AW3FMS	61	RPA-1	62	USG-4VL	51
APTH-12OE9	54	ARDIA-350(HD)(HDE)(HDS)	57	AW3S	60	RPA-2	62		
APTH-12OE10	54	ARDIA-500(HD)(HDE)(HDS)	57	AW6F	60	RPA-3	62	W	
APTH-12OE11	54	ARDIA-750(HD)(HDE)(HDS)	57	AW6FMF	61			WSCH	60
APTH-12OE12	54	ARDIA-1000(HD)(HDE)(HDS)	57	AW6FMS	61				
APTH-12OE13	54	ASC-3	60	AW6S	60			Numbers	
APTH-12OE14	54	ASC-5	60			SH-5	60	1101	31
APTH-12OE15	54	ASH-250C-10MSZ	64			SIW-38PR	34	1102	31
APTH-12OE16	54	ASH-250C-15MSZ	64	B		SIW-50PR	34	1105	31
APTH-12OE17	54	ASH-250C-25MSZ	64	B23	65	SIW-B20LI	34	1115	32
APTH-12OE18	54	ASH-375C-15MSZ	64	B23E	65	SIW-B20LI-HC	34	1121	32
APTH-12OE19	54	ASH-375C-25MSZ	64	B25	65	SIW-C18-20	34	1550	32
APTH-12OE20	54	ASH-375Z	64	BJ10082	36	SIW-P2525Q	34	1577	32
APTH-12OE21	54	ASH-500C-15MSZ	64	BJ10083	36	SIW-P3225Q	34	250-RZ	65
APTH-12OE22	54	ASH-500C-25MSZ	64			SIW-P3238	34	250-SZ	65
APTH-12OE23	54	ASH-500Z	64	E		SIW-P5538	34	2004	22
APTH-12RE50	54	AT3-3	60	EAA-04	59	SIW-P5550	34	2010	21
APTH-12RT25	54	AT3-4	60	EAP-202ASSY	59	SIW-P10050	34	2150	21
APTH-12RT38	54	AT3-6	60	EAP-202ED-KIT	59	SIW-P12050	34	2225	22
APTH-12RT50	54	AT3-9	60	EAP-203-ASSY	59	SIW-PBL	34	2225L	22
APTH-12SD25	54	AT5-3	60	EPTS-33011-25Q	33	SPC-2PGM	36	2240	22
APTH-12SD38	54	AT5-4	60	EPTS-33011P-25Q	33	SPC-A21025	35	2240PEC	22
APTH-12SD50	54	AT5-6	60	EPTS-33017-25Q	33	SPC-A21025Q	35	2263EC	21
APTH-14ADP	54	AT5-9	60	EPTS-33017P-25Q	33	SPC-A21038	35	2403L	24
APTH-14BLANK	54	AT5-12	60	EPTS-33023-25Q	33	SPC-A21625	35		

INDEX

MODEL #	PAGE	MODEL #	PAGE	MODEL #	PAGE	MODEL #	PAGE	MODEL #	PAGE
2450	23	5200EC	7	Bits and Sockets		A3T7-6	70	A611/16-4	67
2463	23	5201EC	7	A128A	68	A3T8-2	70	A613/16	67
2485L	24	5202EC	9	A1220E	68	A3T9-2.75	70	A613/16-4	67
21226	36, 61	5203EC	9	A1418E	68	A3W1-3	69	A614	67
28796	64	5205-2EC	10, 49	A2426E	68	A3W1-4	69	A616	67
2P-15501	23	5206EC	8	A3M8-3	70	A3W2-2	69	A617	67
2P-155034	23	5207EC	8	A3M10-3	70	A3W2-3	69	A617-4	67
25-290015	24	6005	17	A3R1/8-2.75	69	A3W2-4	69	A618-4	67
375-RZ	65	6009	17	A3R9/64-2.75	69	A3W2-6	69	A619-4	67
375-SZ	65	6012	16	A38M8-1	69	A3W2-8	69	A81	67
3100	26	6017	18	A38M10-1	69	A3W2-10	69	A87/8	67
3105	26	6050	48	A38R1/8-1	69	A3W2-12	69	A806A	68
3115	26	6080	48	A38R9/64-1	69	A3W3-2	69	A810E	68
3205	26	6113	18	A38S2-1	69	A3W3-3	69	A815/16	67
3220	26	6114	18	A38S3-1	69	A3W3-4	69	A817	67
3320	26	6115	18	A3B1/4-2	68	A3W3-6	69	A819	67
32046-31-02	6	6115EC	16	A3B1/4-2.5	68	A3W3-8	69	A821	67
4001	44	6116	18	A3B3/8-2	68	A31/4	67	ADC-2S	69
4004	45	6133EC	16	A3B3/8-2.5	68	A31/4C	68	ADC-3S	69
4005	45	6134EC	16	A3B05-2.75	68	A31/4MP	67	ADC-3SH7/16Z	69
4005SC	45	6191	49	A3B5/16-2	68	A33/8	67	ADC-4S	69
4009	44	6507	16	A3B5/16-2.5	68	A33/8MP	67	ADC-4SH7/16Z	69
4010	44	6812EC	49	A3B06-2.75	68	A35/16	67	AM1/4Z	66
4100	44	6905EC	17	A3B07-1.2	68	A35/16MP	67	AM3/16Z	66
4178	44	6906EC	17	A3B07-2	68	A302A	68	AM5Z	66
4260	44	7P-0620-1	31	A3B07-2.75	68	A304C	68	CVF Series Anti-Marring	
4615	45	7P-0620-2	40	A3B07-4	68	A306	67	Sockets	67
4620	45	7P-0620-4	40	A3B07-4	68	A307	67	CV Series Anti-Marring	
5A-0514-2	10, 48	7P-0620-5	40	A3B08-1.2	68	A307-2	67	Sockets	67
5A-1676-7	11	7P-0620-6	40	A3B08-2	68	A307-2.75	67	MARK-XXXX Marker	
5A-04122	9	7P-0620-7	40	A3B08-2.75	68	A308	67	Sockets	66
5A-04202	9	7P-1028-1	31	A3B08-4	68	A308-2	67		
5G-10125	48	7P-1028-4	40	A3B08-6	68	A308MP	67		
5I-03302	6	7P-1028-5	40	A3B08-8	68	A310MP	67		
5I-03302F	6	7P-1028-6	40	A3B09-2.75	68	A310U	68		
5I-04252	7	7P-1028-7	40	A3B09-4	68	A311MP	67		
5I-04252X	8	712P-420	39	A3B10-1.2	68	A311U	68		
5I-06202X	8	712P-5100	39	A3B10-2	68	A375E	68		
5I-06222	7	714P-2100R	39	A3B10-2.75	68	A41/2	67		
5I-06251	7	738P-3200	39	A3B11-2.75	68	A41/2-3.25	67		
5I-10202	7	7005	38	A3B12-1.2	68	A41/4C	68		
5I-10202X	8	7021	65	A3B13-2.75	68	A43/8	67		
500-SZ	65	7021AG	65	A3B14-2.75	68	A43/8-3.25	67		
5000	6	7041A	65	A3B16-2.75	68	A47/16	67		
5001	6	7041AG	65	A3B17-2.75	68	A47/16-3.25	67		
5001C	9	7051	65	A3B55-1.2	68	A403A	68		
5002C	6	7100	38	A3B55-2.75	68	A405C	68		
5003C	9	7102	38	A3B55-4	68	A405E	68		
5006	10	7105	41	A3BHM-3	70	A408	67		
5007	10	7106	41	A3BHM-4	70	A408MP	67		
5008	11	7107	39	A3BHM-6	70	A409	67		
5040	14	7110	38	A3BHM-8	70	A410	67		
5040-6	14	7650	38	A3BHM-10	70	A410-2	67		
5040-6CG	14	730224C	45	A3S0-2	69	A410-3	67		
5040-7G	14	8101	10	A3S1-2	69	A410-3.25	67		
5040-9	14	8102	10	A3S1-2.75	69	A410MP	67		
5040-9G	14	8103	10	A3S1-3	69	A411-3.25	67		
5072	50	8116	49	A3S1-3.5	69	A412MP	67		
5077	50	9020D	28	A3S1-4	69	A412U	68		
5104	11	9024	45	A3S1-6	69	A413U	68		
5105	11	9025	28	A3S2-1.2	69	A504A	68		
5110	6	9025D	28	A3S2-1.6	69	A#508A	68		
5114	50	9043	45	A3S3-2	69	A63/4	67		
5116	8			A3S3-2.75	69	A63/4-4	67		
5194EC	10			A3T6-2	70	A604A	68		
5195EC	10			A3T7-2	70	A610E	68		
5196EC	10			A3T7-2.75	70	A611/16	67		
				A3T7-3.5	70				



Production Tools

EAGLE
G R O U P
A Division of AIMCO

Production Tools S.A de C.V.
Av. Presidente Adolfo Lopez Mateos 8 Ex-Hacienda del Pedregal
Atizapan de Zaragoza Edo de Méx, México C.P. 52966
www.productiontools.com.mx
ventas@productiontools.com.mx
+52 53637600